

M16C/62

Using the M16C/62 Analog to Digital Converter in Repeat Sweep Mode 1

1.0 Abstract

The following article outlines the steps necessary to set up, perform, and read multiple conversions on multiple channels using the onboard analog to digital converter (ADC) of the M16C. The ADC is useful in measuring output voltages of sensors such as accelerometers or other analog instrumentation and converting them to digital values.

2.0 Introduction

The M16C line of devices features an onboard analog to digital converter (ADC). The ADC consists of one 10-bit successive approximation circuit with a capacitive coupled amplifier. There are eight analog input pins, selectable conversion clock speeds, sample and hold function, and several conversion modes. Figure 1 is an overview of the internal circuitry for the ADC block.

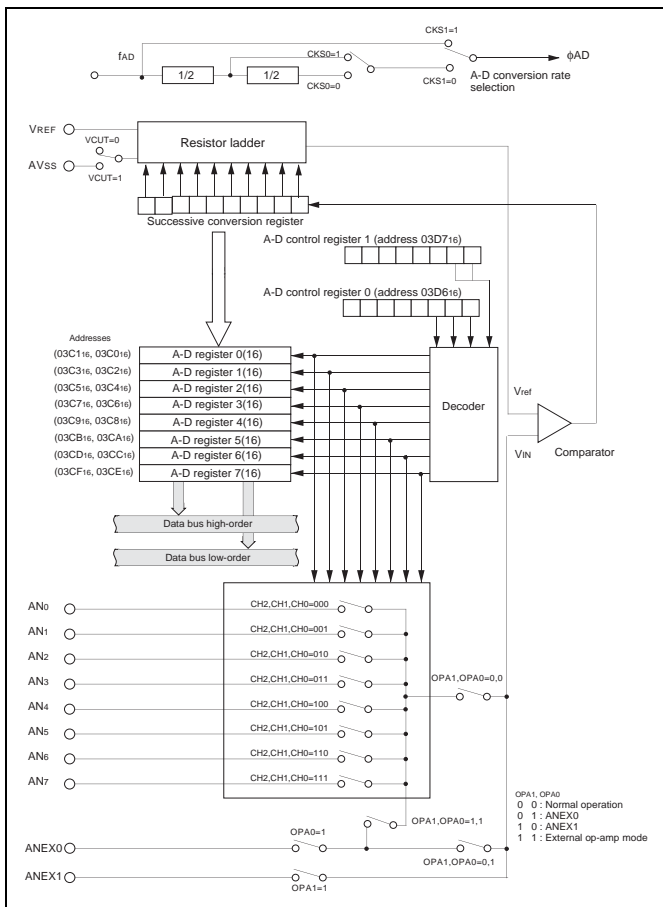

Figure 1 Internal Circuitry for ADC Block—Overview

3.0 Repeat Sweep Mode 1 Description

In repeat sweep mode 1, groups of pins of the ADC can be selected as input sources. Once triggered, a conversion takes place on the selected pins and the results are stored in the ADC result registers corresponding to the selected channels. This is repeated until the ADC conversion start flag is disabled. No interrupt is generated on the completed conversions, but rather the ADC output registers are read to determine the converted values. Figure 2 and Figure 3 are overviews of the registers that will be used in this example. These registers are detailed in the included sample code.

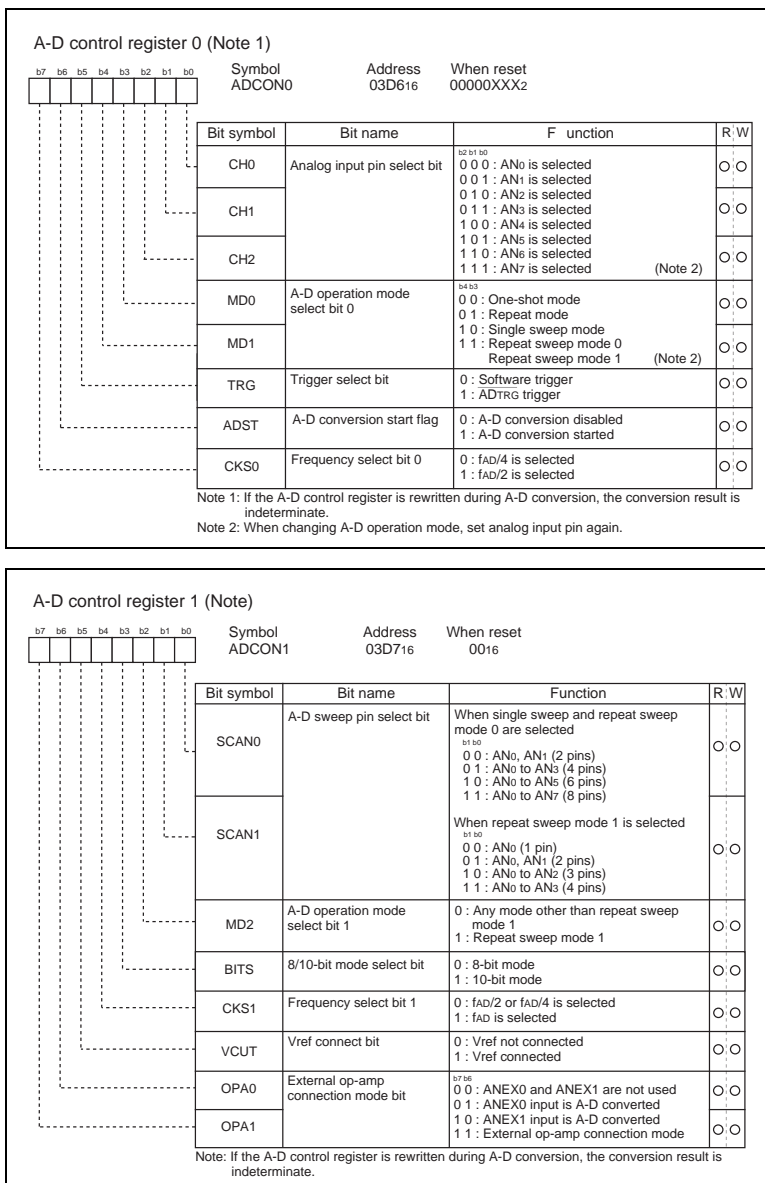

Figure 2 A-D Converter Related Registers

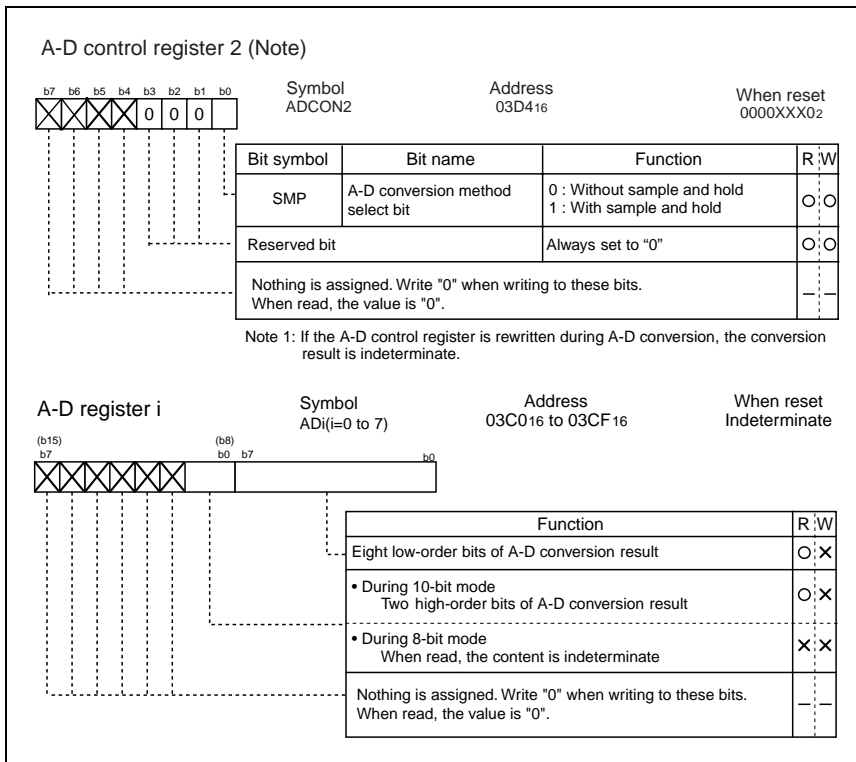

Figure 3 A-D Converter Related Register

4.0 Example Program

This example program demonstrates how to perform a conversion using the ADC in the following environment:

Environment Setup

- Repeat sweep mode 1 conversions
- 10-bit mode
- Analog inputs 0–1 used
- Sample and hold enabled
- Vref connected
- Conversion clock used will be $f_{AD} / 2$ (when $f(X_{in})$ is greater than 10 MHz, f_{AD} must be divided)
- Software conversion start

ADC Software Setup

- Set the ADCON0 register for $f_{AD} / 2$ and repeat sweep mode 1 operation (0x98)
- Set the ADCON1 register for 10-bit mode, f_{AD} divided, AN0-1 sweep, and connect Vref (0x2d)
- Set the ADCON2 register for sample and hold (0x01)
- Enable the A/D converter by setting the ADST bit to 1
- Read current A/D channel values in the variables 'TempStore(x)'

5.0 Reference

Renesas Technology Corporation Semiconductor Home Page

<http://www.renesas.com>

E-mail Support

support_apl@renesas.com

Data Sheets

M16C/62 datasheets, 62aeds.pdf

User's Manual

- M16C/62 User's Manual, 62eum.pdf
- M16C/60 and M16C/20 C Language Programming Manual, 6020EC.pdf
- NC30 Ver. 4.0 User's Manual, NC30UE.pdf

6.0 Software Code

The sample software provided was written using the NC30 compiler. The program starts the conversion process on reset.

```
/*  
 *  
 *   DESCRIPTION: repeat_sweep_mode_1.c  
 *  
 *   AUTHOR: Renesas Technology Corporation, Inc. (June 2003)  
 *  
 *  
 *   PURPOSE: Outlines how to use the M16C/62 ADC in repeat sweep  
 *             mode 1. On reset, program repeatedly stores the results  
 *             of the conversions in variables that can be examined  
 *             using KD30 and the MSV1632-62 Starter Kit  
 *  
 *  
 *  
 */  
*****/  
  
#include "sfr62.h"  
  
int TempStore0 = 0x0000;    // Location where AN0 result is stored  
int TempStore1 = 0x0000;    // Location where AN1 result is stored
```

```

/*
** main
*
* PARAMETERS: None
*
* DESCRIPTION: Main function. Where program execution starts. Sets
*              up the ADC then reads conversion results.
*
* RETURNS: Nothing
*
*/

void main (void){

    adcon0 = 0x98; /*10011000 Repeat Sweep model, software
trigger, fAD/2
                ||||| | _____ analog input select bit 0
                ||||| | _____ analog input select bit 1
                ||||| | _____ analog input select bit 2
                ||||| | _____ A/D operation mode select bit 0
                ||||| | _____ A/D operation mode select bit 1
                ||| | _____ trigger select bit
                || _____ A/D conversion start flag
                | _____ frequency select bit */

    adcon1 = 0x2d; /*00101101 10 bit mode, fADdivided, Vref connected, AN0 & AN1
converted
                ||||| | _____ A/D sweep pin select bit 0
                ||||| | _____ A/D sweep pin select bit 1
                ||||| | _____ A/D operation mode select bit 1
                ||||| | _____ 8/10 bit mode select bit
                ||||| | _____ frequency select bit 1
                ||| _____ Vref connect bit
                | _____ external op-amp connection bit 0
                | _____ external op-amp connection bit 1 */

    adcon2 = 0x01; /* 00000001 Sample and hold enabled
                ||||| | _____ sample and hold select bit
                ||||| | _____ reserved
                ||||| | _____ reserved
                ||||| | _____ reserved
                ||||| | _____ reserved
                ||| _____ reserved
                | _____ reserved
                | _____ reserved
                | _____ reserved */

```

```
adst = 1;                // Start a conversion here

while (1){
    TempStore0 = ad0 & 0x03ff; // Mask off the upper 6 bits of the
                                // variable leaving only the result
                                // in the variable itself

    TempStore1 = ad1 & 0x03ff; // Mask off the upper 6 bits of the
                                // variable leaving only the result
                                // in the variable itself

    }
}
```

Keep safety first in your circuit designs!

- Renesas Technology Corporation puts the maximum effort into making semiconductor products better and more reliable, but there is always the possibility that trouble may occur with them. Trouble with semiconductors may lead to personal injury, fire or property damage. Remember to give due consideration to safety when making your circuit designs, with appropriate measures such as (i) placement of substitutive, auxiliary circuits, (ii) use of nonflammable material or (iii) prevention against any malfunction or mishap.

Notes regarding these materials

- These materials are intended as a reference to assist our customers in the selection of the Renesas Technology Corporation product best suited to the customer's application; they do not convey any license under any intellectual property rights, or any other rights, belonging to Renesas Technology Corporation or a third party.
- Renesas Technology Corporation assumes no responsibility for any damage, or infringement of any third-party's rights, originating in the use of any product data, diagrams, charts, programs, algorithms, or circuit application examples contained in these materials.
- All information contained in these materials, including product data, diagrams, charts, programs and algorithms represents information on products at the time of publication of these materials, and are subject to change by Renesas Technology Corporation without notice due to product improvements or other reasons. It is therefore recommended that customers contact Renesas Technology Corporation or an authorized Renesas Technology Corporation product distributor for the latest product information before purchasing a product listed herein.
The information described here may contain technical inaccuracies or typographical errors. Renesas Technology Corporation assumes no responsibility for any damage, liability, or other loss rising from these inaccuracies or errors.
Please also pay attention to information published by Renesas Technology Corporation by various means, including the Renesas Technology Corporation Semiconductor home page (<http://www.renesas.com>).
- When using any or all of the information contained in these materials, including product data, diagrams, charts, programs, and algorithms, please be sure to evaluate all information as a total system before making a final decision on the applicability of the information and products. Renesas Technology Corporation assumes no responsibility for any damage, liability or other loss resulting from the information contained herein.
- Renesas Technology Corporation semiconductors are not designed or manufactured for use in a device or system that is used under circumstances in which human life is potentially at stake. Please contact Renesas Technology Corporation or an authorized Renesas Technology Corporation product distributor when considering the use of a product contained herein for any specific purposes, such as apparatus or systems for transportation, vehicular, medical, aerospace, nuclear, or undersea repeater use.
- The prior written approval of Renesas Technology Corporation is necessary to reprint or reproduce in whole or in part these materials.
- If these products or technologies are subject to the Japanese export control restrictions, they must be exported under a license from the Japanese government and cannot be imported into a country other than the approved destination.
Any diversion or reexport contrary to the export control laws and regulations of Japan and/or the country of destination is prohibited.
- Please contact Renesas Technology Corporation for further details on these materials or the products contained therein.