

ECGR-6185

Advanced Embedded Systems

Stepper/Servo/DC Motors

University Of North Carolina at Charlotte
A. Srinivas Reddy

DC Motor

Device which converts electrical energy into mechanical energy.

Components

- 1 Rotor
- 2 Stator
- 3 Commutator
- 4 Brushes

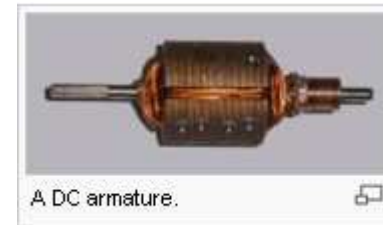

Armature:

The power producing component, it can be either stator or rotor

Functions:

Carries current crossing the field thus creating shaft torque

Generates Electromagnetic force

Working Principle:

Electromagnetism: when a current carrying conductor is placed in the magnetic field there is some mechanical force exerted on the current carrying conductor which is perpendicular to both the conductor and the magnetic field.

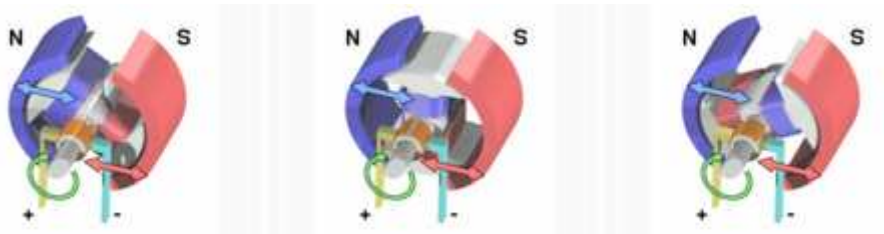

Back EMF:

A moving conductor in a magnetic field gets a voltage induced across, which is in opposite polarity to the applied voltage. Known as back EMF.

Armature converts the electrical power into the Mechanical torque and transfers it to the load via shaft.

The current through a motor is given by the following equation:

$$I = (V_{\text{applied}} - V_{\text{bemf}}) / R_{\text{armature}}$$

The mechanical power produced by the motor is given by:

$$P = I * V_{\text{bemf}}$$

The back EMF is dependent on the speed of the motor

No Load Speed: Initially

$$V_{\text{bemf}} = 0$$

$$I = V_{\text{applied}} / R_{\text{armature}}$$

Large mechanical force induces a back EMF approx equal to the applied voltage. The motor rotates but does not drive any current.

Under Load:

Speed (reduces) => Back EMF (reduces)

Speed Control of DC Motor (Using Half Bridge Circuit):

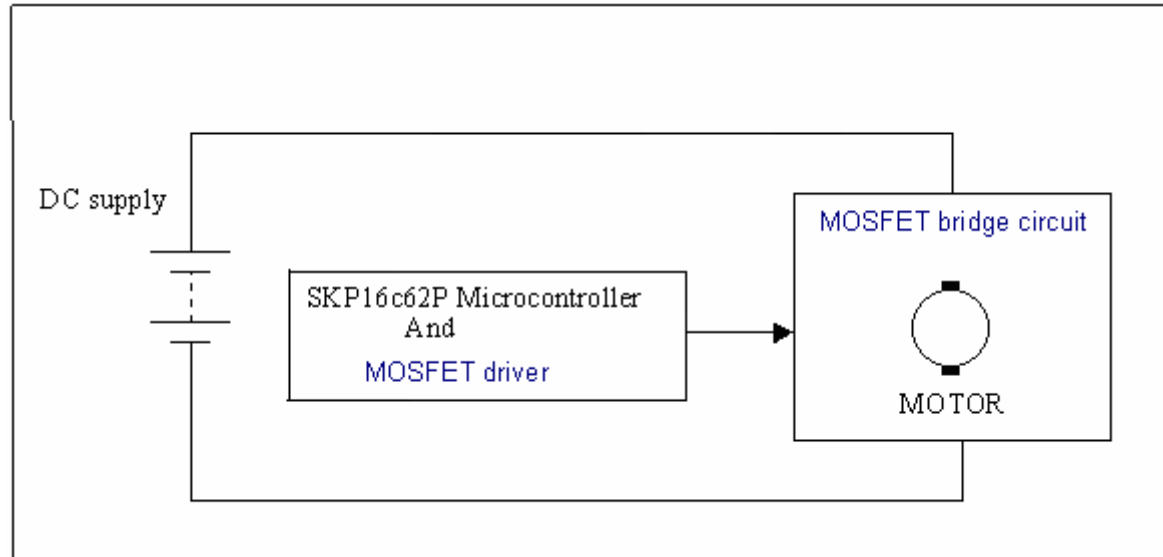

Steps

1. Calculate the no load speed for the applied voltage.
2. Read the speed of the motor under load and provide a feedback to the controller.

Control logic of the micro-controller

Convert the analog value of the feedback speed to digital value using A/D converter.

```
/* ADC initialization */
/* Configure ADC - AN2 (Analog Adjust Pot) */

adcon0 = 0x8A;           // AN2, repeat sweep mode,
                        // software trigger, fAD/2
adcon1 = 0x29;           // AN2, 10-bit mode, Vref connected.
adcon2 = 0x01;           // Sample and hold enabled
adst=1;                  // start the A/D Conversion
```

Set the timer to generate PWM signal.

```
#define PWM8_CONFIG 0x67
```

```
/* 01100111 value to load into timer A0 mode register
   |||||_ TMOD0,TMOD1: PWM MODE SELECTED
   |||||_ MR0: = 1 FOR PWM MODE
   ||||_ MR1,MR2: EXT TRIGGER NOT SELECTED
   ||_ MR3: SET TO 1 FOR 8BIT PWM
   ||_ TCK0,TCK1: F DIVIDED BY 8 SELECTED*/
```

```
ta1mr = PWM8_CONFIG;
ta1 = 0x00 // initialize n & m to 0
ta1ic |= 0;
ta1s = 1; //start timer A1
```

.

Set the timer to read the A/D value of the feedback voltage for every 1 second.

```
tb0mr = 0x80;
tb0=2000;
tb0ic = 1;           // Timer B0
tb0s = 1;           // start timer B0
```

Set the Pulse width of the PWM signal.

```
void tb0_irq()
{
    if(feedback>=0 && feedback<=1023) // ADC uses 10 bit
resolution
    {
        RED_LED^=1;
        pwm8 = 250;
    }
}
```

Typical Connection

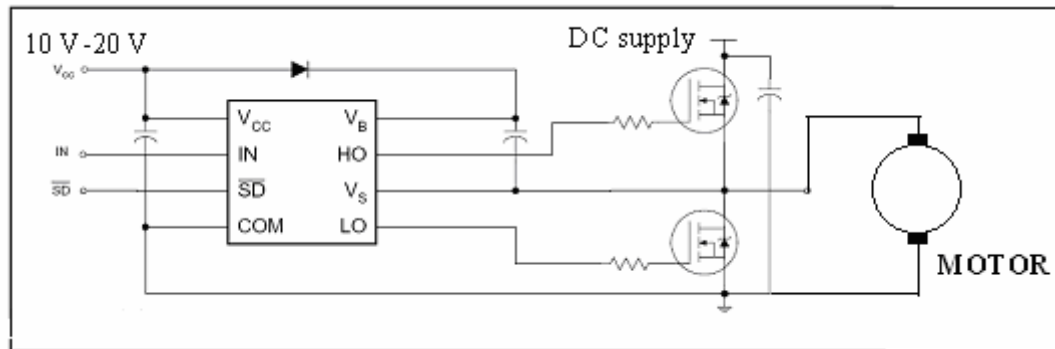

The Components

- Regulated power Supply
- IR2104 Driver
- Half bridge Circuit using MOSFETs
- DC motor

The operating Conditions of IR2104 FET Driver

Symbol	Definition	Min.	Max.	Units
V_B	High side floating supply absolute voltage	$V_S + 10$	$V_S + 20$	V
V_S	High side floating supply offset voltage	Note 1	600	
V_{HO}	High side floating output voltage	V_S	V_B	
V_{CC}	Low side and logic fixed supply voltage	10	20	
V_{LO}	Low side output voltage	0	V_{CC}	
V_{IN}	Logic input voltage (IN & \overline{SD})	0	V_{CC}	
T_A	Ambient temperature	-40	125	°C

Note 1: Logic operational for V_S of -5 to +600V. Logic state held for V_S of -5V to $-V_{BS}$.

MOSFET:

MOSFETs are high power application reactive component of all the switching components. It is a high speed switching element.

Operation

The PWM signal generated by a micro – controller is given to IR2104 FET Driver. The IR2104 driver is a high voltage high speed MOSFET driver with dependant high and low side different output Channels (VHO and VLO)

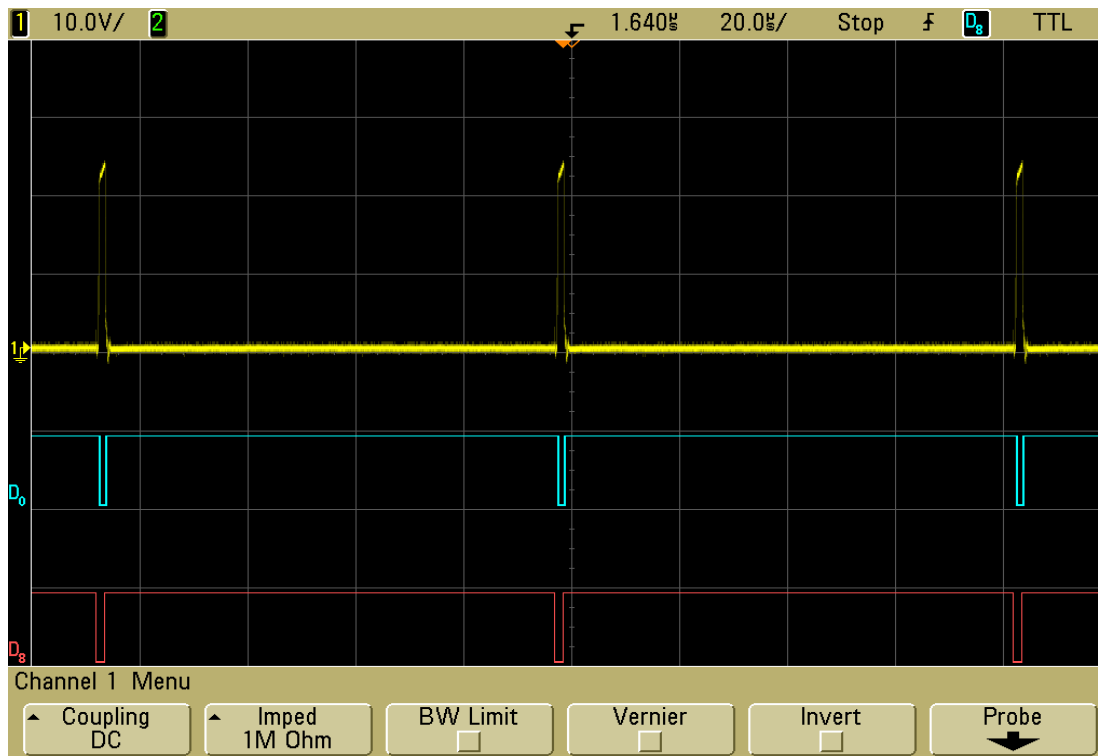

Red- PWM signal generated from SKP16c62p
Blue- High output signal from gate driver
Yellow- Low output signal from gate driver

```
Void main()
{
while (1)
    {
        feedback=ad2;

        while(time_cnt <10000)
            time_cnt++;           // delay loop

        time_cnt = 0;

        ta1 = (pwm8 << 8) & 0x0FF00;    // set high order (n)
    }
}
```

Stepper Motor:

It is a brushless DC Motor whose rotor rotates in discrete angular increments when the stator windings are energized in the programmed manner.

The Rotor has no electrical windings
it has magnetized poles

It is also known as digital actuator

Operational Modes

- Full step mode
- Half step mode
- Micro step mode

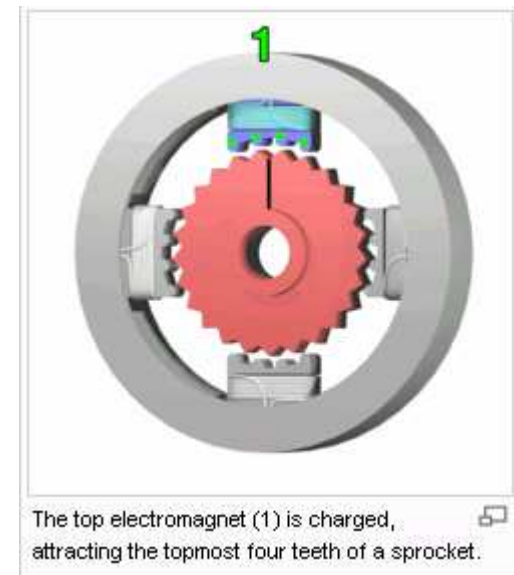

Operation:

Stepper Motor operation is synchronized by the command pulse signals generated by the Pulse generator.

Stepper Motor has a open loop Control System

Stepper motor

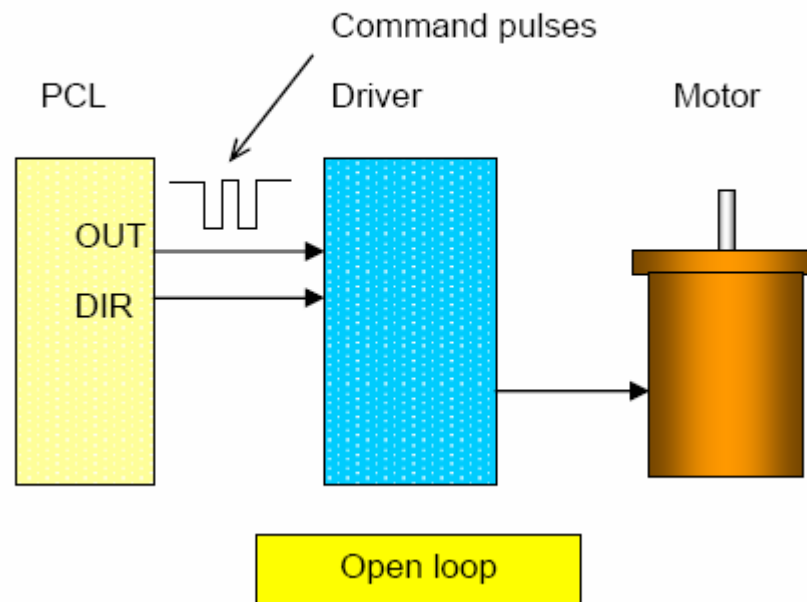

Control:

For sequential energisation of the stator windings we can either use the pulse generator or micro-controller for generating PWM signals.

In order to make pulse per rotation and set the direction of the rotation, two pulse trains of same cycle and phase shifted are supplied by the pulse generator.

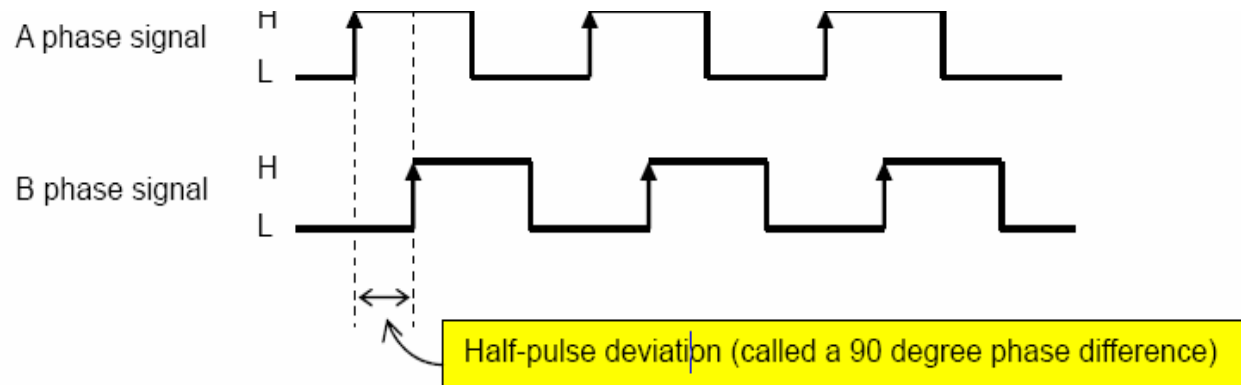

Relationship between the Input Command Pulses and the motor rotation:

— : Command pulses output from the PCL
..... : Actual motor rotation

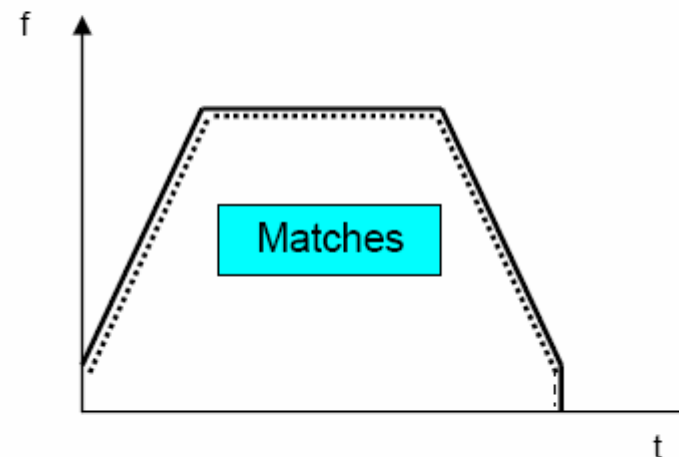

Operates by following the command pulses.

Applications:

Floppy Disk Drives
Flat bed scanners printers
Plotters

Servo Motor:

Servos are DC motors with built in gearing and feedback control loop. It has closed loop control system.

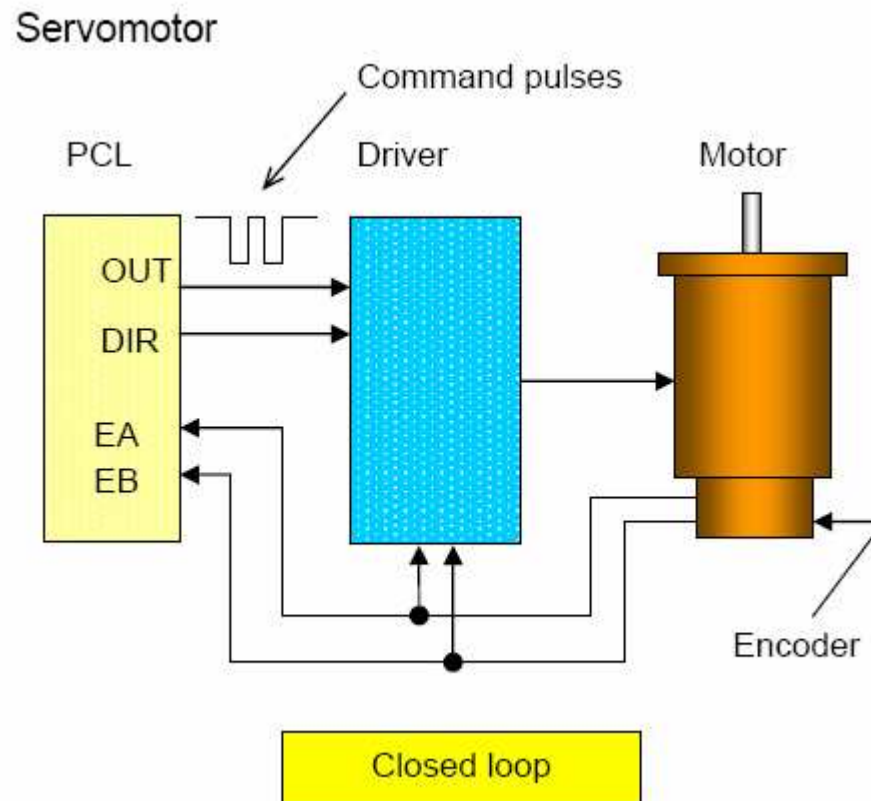

Working principle:

It works on the principle of negative feedback.

The Control information is compared with the actual position of the motor

Relationship between the I/P command pulses and the actual motor rotation:

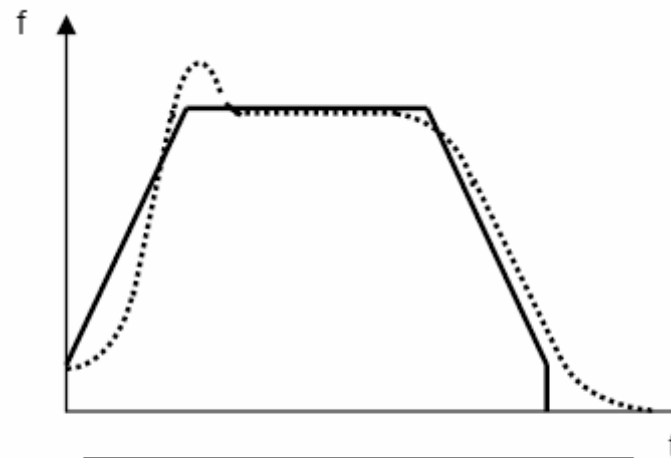

Operation lags behind the command pulses

The servo motor rotation lags behind the command pulses which results in an error signal(E_a, E_b).

A deflection counter

Compares the number of pulses returned from the encoder(P_e) with the command pulses(C_p).

```
If( $P_e > C_p$ )
{
    driver rotates the motor back word.
}
If( $P_e < C_p$ )
{
    driver rotates the motor forward
}
If( $P_e = C_p$ )
{
    motor stops
}
```

Applications:

CNC machines

They use servomotors to make the motion axis of the machine tool follow the desired path.

Automobiles

To amplify the steering and braking force applied by the driver.

Differences between Servo & Stepper Motors

	Stepper motor	Servomotor
Drive circuit	Simple. The user can fabricate it. (The customer just purchases a motor, creates a control circuit and starts the motor rotating.)	Since the design is very complicated, it is not possible to fabricate your own driving circuit. (Therefore the motor and driver are sold as a set.)
Noise and vibration	Significant	Very little
Speed	Slow (1000 to 2000 rpm maximum)	Faster (3000 to 5000 rpm maximum)
Out-of-step condition	Possible (will not run if too heavy a load is applied)	Not possible (will rotate even if a heavier load is applied)
Control method	Open loop (no encoder)	Closed loop (uses an encoder)
Price of motor and driver	Cheap (100 to 200 US\$ per set) (If you produce your own driver, the cost will be only a few 10 US\$)	Expensive (more than 400 US\$)
Resolution (single-step angle)	2-phase PM model: 7.5° (48 ppr) 2-phase HB model: 1.8° (200 ppr) or 0.9° (400 ppr)	Depends on the encoder's resolution. Generally speaking, 0.36° (1,000 ppr) to 0.036° (10,000 ppr)