



University of North Carolina at Charlotte
ECGR-6185
ADVANCED EMBEDDED SYSTEMS

A decorative graphic on the left side of the slide, consisting of a vertical black line intersecting a horizontal black line. To the left of the intersection are three overlapping squares: a blue one on top, a red one on the left, and a yellow one on the bottom.

SMART CARDS

Sravanthi Chalasani

sravanthi chalasani



Overview

- § Introduction
- § History of smart cards
- § Types of smart cards
- § Categories of smart cards
- § Smart Card Standards
- § SLE4442 EEPROM Chip
- § Applications of Smart cards
- § Future Aspects
- § Conclusion

What is a Smart Card?



Ref:10

§ Smart Card is a small plastic intelligent token embedded with an IC chip that makes it '*SMART*'.

§ Smart Cards provide computational capability along with memory capacity.

§ Smart Cards can be used with a *Smart-Card Reader* attachment to a personal computer to authenticate a user.



History of Smart Cards

- n Smart Card has its origin in 1970s by inventors from Germany, Japan and France.
- n Until mid 80s most of the work on Smart Cards was at the research and development level.
- n First mass use was for payment in French payphones.
- n The current world population of Smart Cards is nearly 3 billion.
- n The manufacturers of Smart Cards are Gemplus, IBM, Siemens, Telesec and many more.

What is SMART about the Smart Card ??



Ref:1

- n Smart Cards are capable of not just storing data but also have processing power.
- n They have larger storage capacity when compared to magnetic swipe cards.
- n The data stored can be protected against unauthorized access and tampering.
- n They are appropriate for secure and convenient data storage.
- n Smart cards have the property of multifunctionality.

Types of Smart Cards



Based on the way the smart card interacts with the Reader, smart cards are of two types

Ref:9

Contact Smart Cards: These require insertion into the Card reader.

Contact less Smart Cards: These require close proximity of the reader.

Continued..

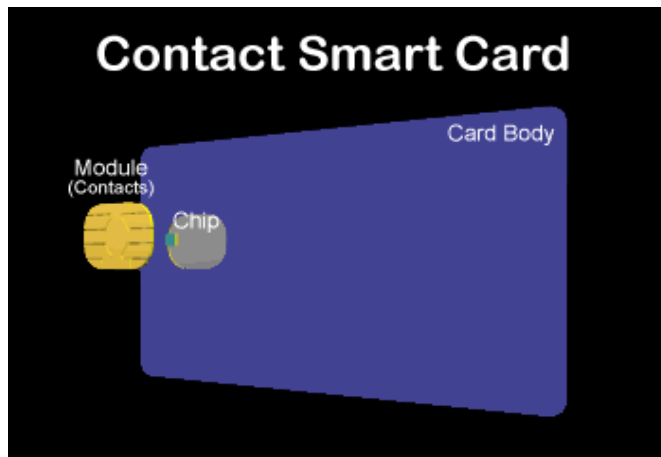

Ref:7

§ the contact smart card consists of small contact plate on the face, which is ½” in Diameter.

§ The transmission of data takes place when this contact plate comes in contact with the connector of the reader.

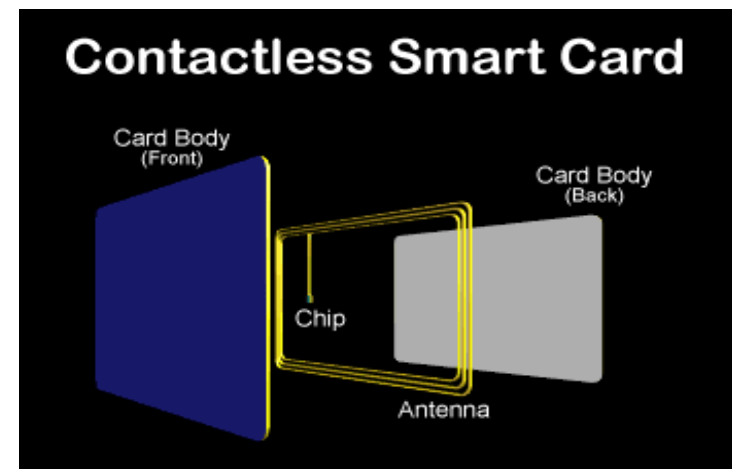

Ref:7

§ This card consists of an IC Chip and an antenna coil embedded into it.
§ These cards are mainly used when transactions must be processed quickly.



Categories of Smart Cards

Based on the type of IC chip embedded on the Smart Card, they are categorized into three types

- § IC Micro Processor Cards
- § IC Memory Cards
- § Optical Memory Cards



Smart Card Standards

ISO7816 is the international standard for Smart Cards that use electrical contacts.

With this standard, Smart Cards could communicate with the Reader using the same protocol.

The ISO7816 standards are separated in 3 different parts.

- n *ISO7816-1*: defines the physical characteristics of the card.
- n *ISO7816-2*: defines the dimension and contact position of the card.
- n *ISO7816-3*: defines the electrical signals and transmission protocols.



Continued..

Operating procedure for contact smart cards is

- n Connection and activation of the contacts
- n reset of the card
- n answer to reset by the card
- n information exchange
- n deactivation of the contacts



SLE4442

Intelligent 256 Byte EEPROM with Write Protect Function and Programmable Security Code (PSC)

FEATURES:

- § Byte wise addressing
- § 32 bit protection memory
- § ISO standard compliant
- § Synchronous Transmission
- § 3-Byte PSC

Pin Configuration



VCC	C1	C5	GND
RST	C2	C6	NC
CLK	C3	C7	I/O
NC	C4	C8	NC

Electronic modules embedded in smart cards have contacts by which messages can be exchanged.

Ref:3

Memory Overview

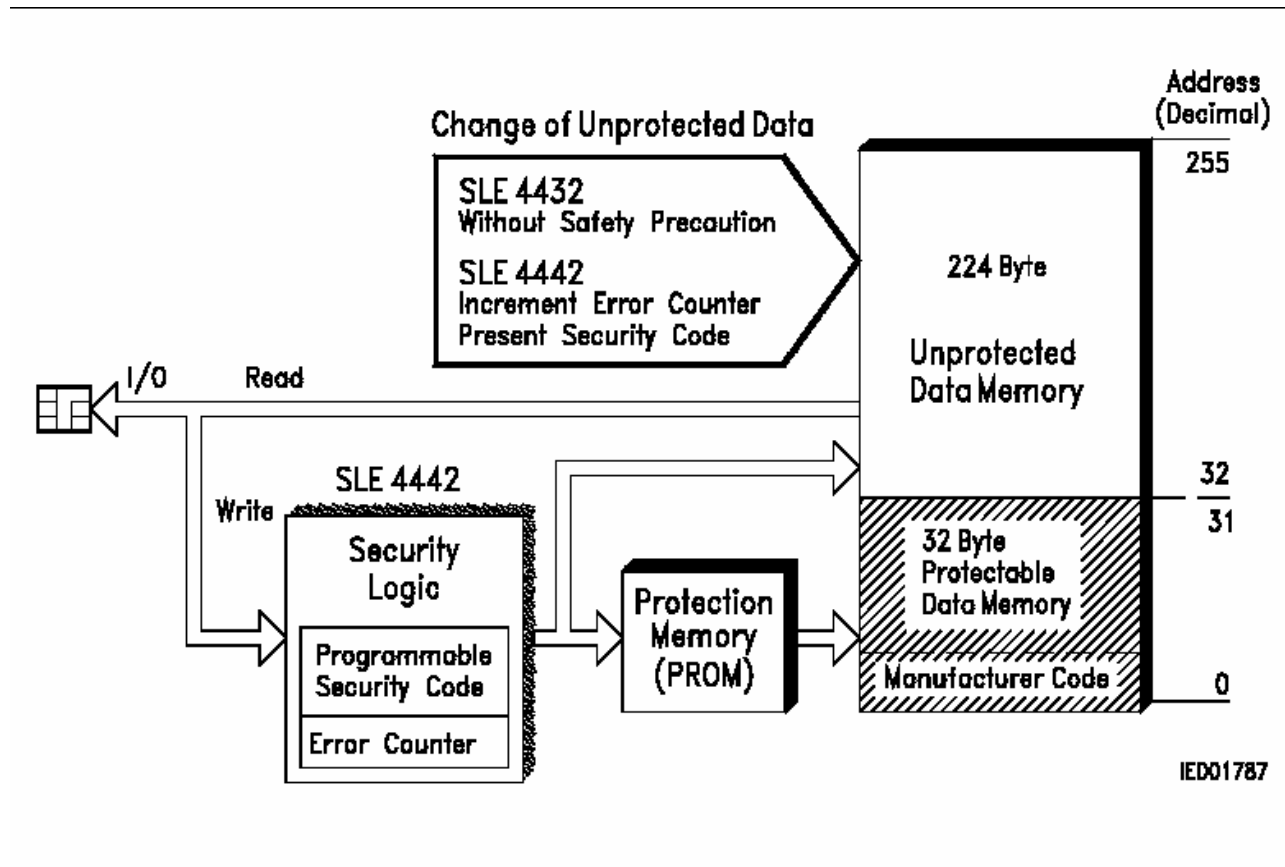

Ref:6



Transmission Protocol

The Transmission Protocol is a two-wire link protocol between the IFD and IC.

The 4 modes are:

Reset and Answer-to-Reset (ATR).

Command Mode.

Outgoing data Mode.

Processing Mode.

Reset and ATR

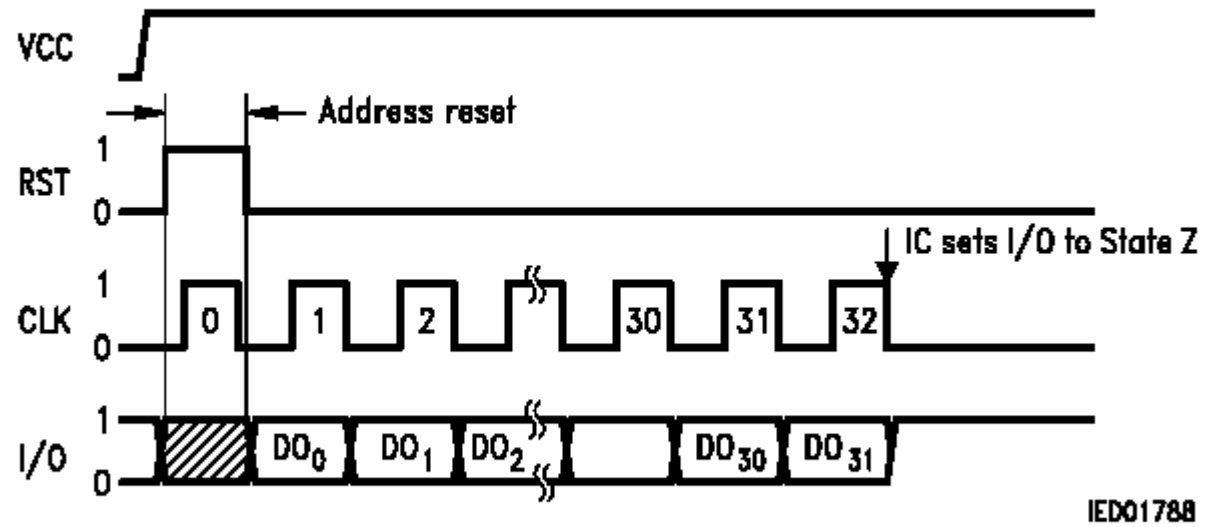

Operating Mode

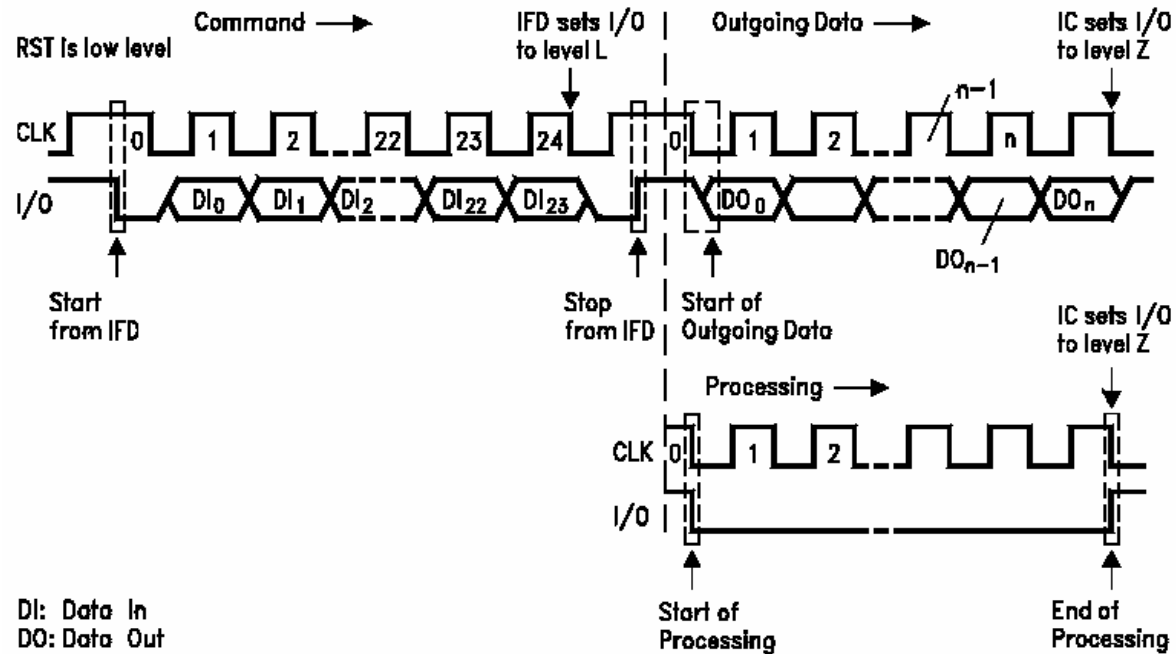

Ref:6



Command Format

Byte 1 Control								Byte 2 Address	Byte 3 Data	Operation	Mode
B7	B6	B5	B4	B3	B2	B1	B0	A7-A0	D7-D0		
0	0	1	1	0	0	0	0	address	no effect	READ MAIN MEMORY	outgoing data
0	0	1	1	1	0	0	0	address	input data	UPDATE MAIN MEMORY	processing
0	0	1	1	0	1	0	0	no effect	no effect	READ PROTECTION MEMORY	outgoing data
0	0	1	1	1	1	0	0	address	input data	WRITE PROTECTION MEMORY	processing

Table 2
SLE 4442 only

0	0	1	1	0	0	0	1	no effect	no effect	READ SECURITY MEMORY	outgoing data
0	0	1	1	1	0	0	1	address	input data	UPDATE SECURITY MEMORY	processing
0	0	1	1	0	0	1	1	address	input data	COMPARE VERIFICATION DATA	processing

Ref:6



Programmable Security Code

- n PSC is 3-bytes of Reference data used along with 1-byte of EC.

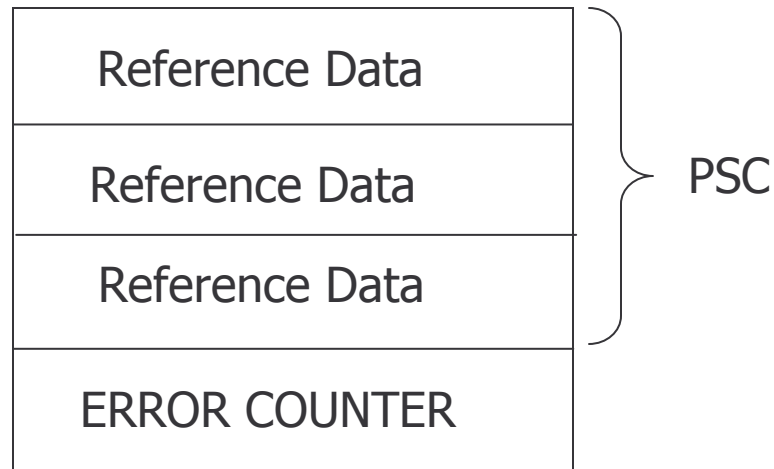

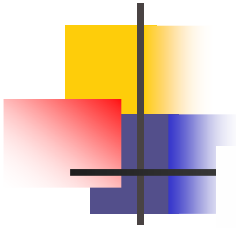

Verification Procedure

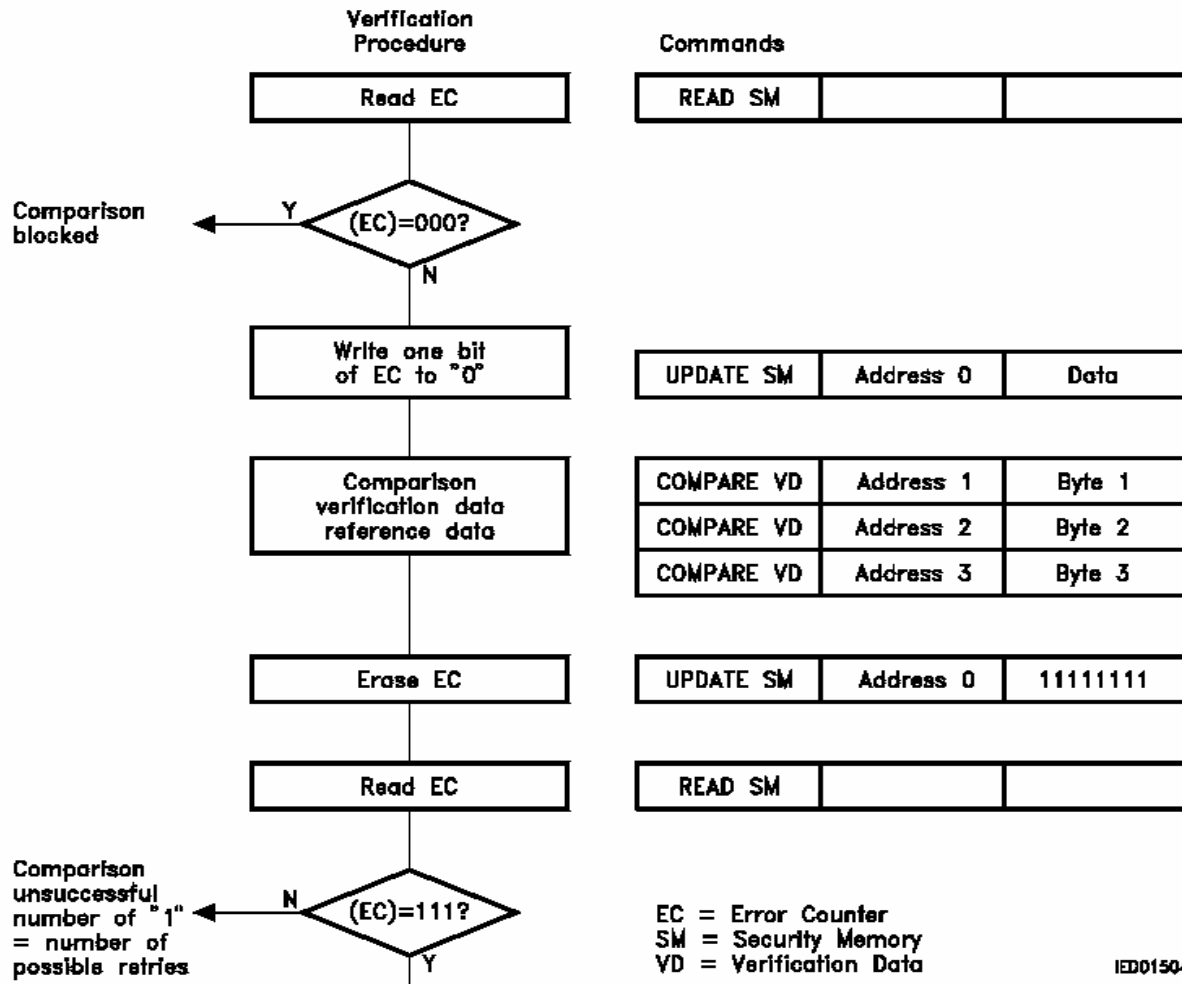



Applications of Smart Cards

- § *In Banks:* They are used as credit/debit bank cards
- § *Medical applications:* they can be used as Health insurance card or Medical File Access Card.
- § *In Transportation Services:* for urban parking, Airline Application and Electronic Toll Collection.
- § *In Telecommunications:* The smart cards contain the phone number on the network, billing information and call numbers.
- § used as identification cards



Future Aspects

- n Soon it will be possible to access the data in Smart cards by the use of Biometrics.
- n Smart card Readers can be built into future computers or peripherals which will enable the users to pay for goods purchased on the internet.
- n In the near future, the multifunctional smart card will replace the traditional magnetic swipe card.

Smart Card is not only a data store, but also a programmable, portable, tamper resistant memory storage.



References

1. <http://www.ewh.ieee.org/r10/bombay/news5/SmartCards.htm>
2. <http://www.smartcardbasics.com/overview.html>
3. <http://www.smartcardsupply.com/Content/Cards/7816standard.htm>
4. http://www.mobilein.com/smart_cards.htm
5. http://www.cardwerk.com/smartcards/smartcard_technology.aspx
6. Data sheet of SLE4442 chip
7. <http://www.smartcardindia.org>
8. Smart Card Hand book
9. www.hitachi.co.jp/.../service/2004034_12381.html
10. www.itsdocs.fhwa.dot.gov/.../REPTS_TE/13769.html

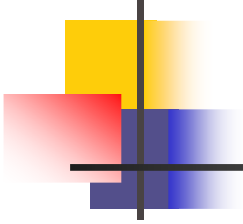

THANK YOU J

Sravanthi Chalasani

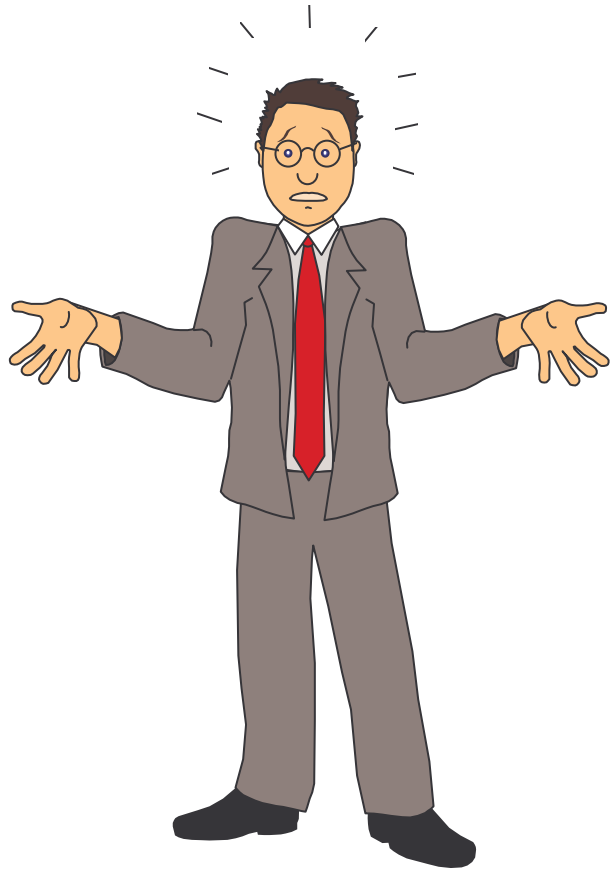
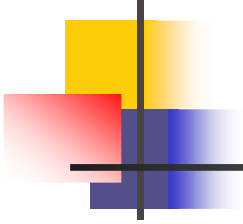

QUERIES ?