

# Design of a Data Communications Hub for use in Research and Education

## Abstract

*In this paper we present the design of a data communication hub for use in research labs and classroom teaching. One main aim of the communication hub is to provide embedded system students hands-on experience in handling data communication by using several technologies. The board includes four distinct communication hardware subsystems: optical fiber, infrared, RS232 serial communication, and USB serial communications. This paper identifies the need of such a communication hub for teaching. The later part of the paper presents the design of the board in detail and the various data communication modules used along with their speeds and throughputs.*

*The use of the communication educational board for classroom teaching will help students obtain the kind of practical exposure which they can not get through theoretical studies. Lab exercises and test code provided with the board can be used by students in the lab to test the various data communication techniques and determine the data rate and bit error rates. The student will be capable of programming the board for different functionalities. Keywords: Optical, embedded, communications, infrared.*

## 1. Introduction

Data communication is one of the most fundamental and important parts of any electronic or electrical equipment in use today. Control systems that are embedded inside industry-grade high technology equipment or a part of many household electrical appliances require data communication either within the system, between the various components involved in that system or outside the system. Data communication forms the backbone for any electronic system. Data may be carried to a distance of less than a fraction of an inch on a printed circuit board to as far as kilometers through long wires or via different wireless methods. The basic aim of each device capable of data communications is to transmit and/or receive data at the highest possible transmission speed with the lowest possible transmission error, consume lowest possible power, and cost the least amount of money possible.

Data is transmitted through communication channels, which are pathways through which data flows from the transmitter to the receiver.

Communication channels can vary depending upon the type of application and the transmission requirements. Simplex, half duplex, duplex are some of the different types of channels that are used for data communications. In a digital communication channel, the data is represented by individual bits which may be combined to form multi bit message units. A byte is an example of a message unit that may be conveyed through a communication channel.

There has been enormous growth in the field of optical communication in recent years. A significant amount of technological research and development is being done in optical communication. Many embedded systems have integrated optical communication as the means of faster and reliable data transfer. The integration of optical communication in many embedded systems has forced the embedded engineers to have knowledge about the science and technology behind it.

Although the field of optical communication has many applications, optical fiber is one area which has revolutionized optical data communication. Optical fibers are thin, transparent strands almost the size of a human hair made from a dielectric cylinder surrounded by another transparent dielectric cylinder. The fibers are used as light waveguides to transmit light energy at optical wavelengths. The light travels inside the fiber using a series of reflections from wall to wall between the two transparent cylinders. The reflections inside the walls are possible because of high refractive index material of the inner cylinder and the low refractive index of the outer cylinder, also known as total internal refraction. The use of optical fibers as a means of communication is mainly because of their very low fabrication cost, low signal loss, and extremely low interference and capability of high data transfer rate at very low power.

Wireless infrared transmission or simply IR is one more area of optical communication which has wide range of applications like remote control, telemetry and health care. Infrared emitters and detectors are capable of high-speed transmissions and are available at a very low cost making them more popular for some data transmission applications.

The wide range of application of optics in almost every field, and particularly in the field of electrical and computer engineering, makes it important that engineers have certain knowledge about optics. The need for a device or a communication hub arises to overcome this lack of knowledge.

The goal of this design effort was to create a communication hub or a communication educational board that can be used in labs and classrooms to teach data communication to embedded system engineering students. The communication educational board carries different modules capable of data communication between two such similar boards, between the board and a PC or between two PCs via the communication board. The board has been designed keeping into view that it will be used by students to learn data communication using different communication modules in embedded system courses.

Students taking embedded systems courses can make use of this educational board to not only learn the basics of the embedded system itself but at the same time get a good amount of exposure to data communication using optical fiber and infrared. Data communication using serial RS232, USB and simple I/O can be practiced in addition to the optical data communication, and all this in one single board makes learning simpler and easier.

This board is one of its kinds and can be used by universities to teach embedded system courses using it for lab exercises. Students can program the board for data communication at different rates and with different communication channels. A student will be able to calculate transmission rates and transmission errors using the various transmitters and receivers present on this single board. This paper covers the design details of the board.

## 2. PREVIOUS WORK

Embedded system is one of the fields where data communication holds a very important place. Embedded communication devices are integrated into different applications ranging from homeland security system to industry automation to simple home appliances. With these significant technological advancements in the field of data communication and the subsequent development of high technology equipment and gadgets comes the need for teaching the latest technology in data communication to the upcoming engineering students. The demand of embedded engineers having knowledge about data communication is going to be high. However there are very few development tools available for classroom teaching, so the engineering students usually do not learn much about different data communication technologies.

Communication theory and analytical models are often considered dry by students, leading to poor retention of the material. Understanding these concepts is an important part of understanding approaches required to solve real world problems. Therefore, a pedagogical goal is to develop hands-on

learning modules for communications courses. There is a substantial body of work relating to the advantages and approaches for integrating course work with laboratory investigation [1-9] in order to illustrate concepts in communications. Of particular interest is the three-level approach [1-3] where the student is introduced to 1) component level, 2) sub-system level and then 3) system level experiments. It is anticipated this approach will be adopted for courses which use this communications hub board, and is one of the primary motivations for developing this board.

## 3. Board Design

Figure 1 shows the general block diagram of the communication educational board. All the important communication modules which have been used in the board, like infrared transceiver, optical fiber transceiver, RS232 port and the USB port have been shown along with the direction of data flow. Status LEDs like transmit, receive, power and bit error have been added to the board to give additional functionalities and user friendly interface to the board. A number of switches used for debugging purposes have been incorporated in the design as well.

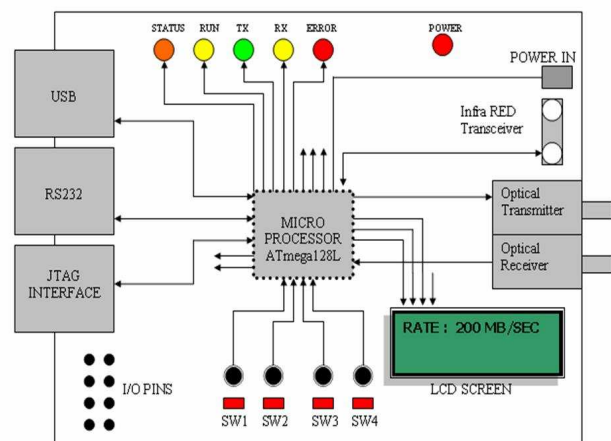

FIGURE 1  
BLOCK DIAGRAM OF THE DATA COMMUNICATIONS BOARD.

### 3.1. Board Specifications

The communication educational board is a small sized communication hub capable of handling different kinds of data communication. Optical fiber, infrared, RS232 and USB are some of the modules which can handle data communication on the board. Each of these module is independent of each other and works at different baud rates depending upon their specification. The board is powered through a DC voltage supply between 9V to 15V. The board carries a voltage

regulator which brings down the voltage to 5V. The voltage regulator circuit has been specifically designed for this board. The board can also be alternatively powered through the USB port, giving the port additional functionality. All the components on the board have been chosen in order to operate in this voltage range. To make the board work as a low power communication hub, low power consuming devices including the microcontroller have been chosen with no or very less compromise with the price. The board though still in its design stage will be small in size. The components have been chosen such that the size of the board does not increase beyond 4 square inches. Surface mount resistors and capacitors of standard size 0603 (~1.6mm) have been chosen. These components immensely reduce the over all layout complexity and the size of the board. The board has been equipped with a LCD screen, giving it an additional user friendly look. Baud rates, bit error and/or current state of the microcontroller are some of the things that can be displayed on the LCD screen by programming the board. The ATMEL ATmega128L is the microprocessor used on the communication board. To make the programming of the board easy, AVR Studio® 4 will be used. The AVR Studio® 4 is the professional Integrated Development Environment (IDE) for writing and debugging AVR® applications in Windows® 9x/NT/2000/XP environments. AVR Studio® 4 includes an assembler and a simulator. The communications kit will come along with a number of test codes along with the board which can be downloaded on the board through the PC using a JTAG connector. The test codes will be able to test the functionality of each module on the board. A user will be able to alter and improve upon those test codes depending upon the requirement.

### **3.2. Board Functionality**

Before the design of the board was started we had to decide upon the different data communication modules that will be used on the communication educational board. The optical communication transceivers which include both fiber optic and infra red transceivers form the main data communication ports on the board. The entire board has been initially designed based upon these two data communication channels. However apart from the optical communication, the board will be capable of handling serial data communication through the serial RS232 port. In addition to the serial port a USB port has also been provided. The USB port will be capable of handling data communication and in addition provide an alternate power source to the board. The JTAG interface present on the board is used for downloading code from the PC to program the microcontroller. The Board has been designed

specifically for educational purposes. The board functionalities can be used to demonstrate data communication in embedded system or optical communication classes. Engineering students working with the communication educational board will get hands on experience in programming of the microcontroller for handling data communication using different communication channels present on the board. The board in general will be capable of handling data communication between the different modules of the board, between the PC and the board and between two PCs via the communication board.

## **4. Board Components**

### **4.1. Microcontroller**

The microcontroller chosen for this board is the ATMEL ATmega 128L. It is a high performance, low power, 8 bit AVR® microcontroller. It has a 128Kbytes of self programmable flash, 4Kbytes of EEPROM and 8Kbytes of internal SRAM [10]. The microcontroller comes with a JTAG interface for programming. The processor speed ranges from 0 to 16 MHz in the voltage range of 4.5 to 5.5V. As far as the data communication is concerned the ATmega128L carries two programmable UARTs. It is capable of Master/ Slave SPI interface and byte oriented 2-wire serial interface. A comprehensive set of development tools are available for the ATmega128L microcontroller. The microcontroller is programmed using AVR Studio® 4. The Universal Synchronous and Asynchronous serial Receiver and Transmitter (USART) is a highly flexible serial interface device present in the microcontroller. It supports full duplex operation (independent serial receive and transmit registers), master or slave clocked synchronous operation and high resolution baud rate generator. It supports serial frames with 5,6,7,8 or 9 data bits and 1 or 2 stop bits. At an oscillator frequency of 20MHz it is capable of handling data rates of up to 2.5Mbps. With all this serial data communication support and more, it made the choice of the microcontroller for the communication board easy and un-debatable.

### **4.2. Optical Transceiver**

The optical transceiver used for fiber optic data communication is the HFBR-5103 [11]. The HFBR-5103 optical transceiver from Agilent Technologies provides us with a design to implement a range of FDDI (Fiber Distributed Data Interface) and ATM (Asynchronous Transfer Mode) at 100Mbps/125 Mbps rate. The HFBR-5103 is useful for both ATM 100 Mbps interfaces and Fast Ethernet 100 Base-FX

interfaces. When used in ATM and FDDI applications the HFBR-5103, 1300nm transceiver is guaranteed by Agilent technologies to give signaling rates of over 10MBd to 125MBd.



FIGURE 2  
HFBR 5103: OPTICAL FIBER TRANCEIVER

The transmitter sections of the HFBR-5103 series utilize 1300 nm Surface Emitting InGaAsP LEDs. These LEDs are packaged in the optical subassembly portion of the transmitter section. The receiver sections of the HFBR-5103 series utilize InGaAs PIN photodiodes coupled to a custom silicon transimpedance preamplifier IC. These are packaged in the optical subassembly portion of the receiver. The overall package concept for the Agilent transceivers consists of the following basic elements; two optical subassemblies (the receiver and the transmitter), an electrical subassembly and the housing. The electrical sub assembly comprises of the Quantizer IC and the Driver IC. The preamplifier IC of the receiver section is connected to the custom quantizer IC which provides the final pulse shaping for the logic output and the Signal Detect function. The data output is differential. The signal detect output is single-ended. Both data and signal detect outputs are PECL (Positive Emitter Coupled Logic) compatible, ECL referenced (shifted) to a +5 Volt power supply.

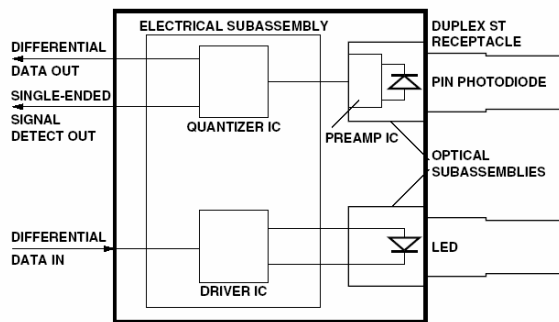

FIGURE 3  
BLOCK DIAGRAM OF THE HFBR 5103

The package comes with internal shielding for both the electrical and optical subassemblies to ensure low EMI (Electro Magnetic interference) emissions

and high tolerance to external EMI fields. The outer housing including the duplex SC/ST connector receptacle is molded out of filled non-conductive plastic to provide mechanical strength and electrical isolation.

### 4.3. Infrared Transceiver

Another optical communication module used in the data communication board is the infrared transceiver module. The IR transceiver used in the hub is the TFDU4100 Serial Infrared Transceiver (SIR) from Vishay Semiconductors [12]. The TFDU4100 is an infrared transceiver module compliant with the IrDA (Infrared Data Association) standard for serial infrared (SIR) data communication, supporting speeds up to 115.2kbit/s. The transceiver module consists of a PIN photodiode, an infrared emitter (IRED), and a low-power analog control IC to provide a total front end solution in a single package.



FIGURE 4  
TFDU4100: INFRARED TRANCEIVER

The TFDU4100 SIR transceiver comes in a small Baby Face package. The transceiver is capable of directly interfacing with a wide variety of microcontrollers. The wide area of applications that the SIR can be used in makes it an ideal data communication module to be selected for the communication Hub for teaching purposes. Some of the examples where the TFDU4100 SIR transceiver can be used are Printers, Fax machines, copiers, cellular phones, pagers, handhelds, medical and industrial data collecting devices, GPS and more.

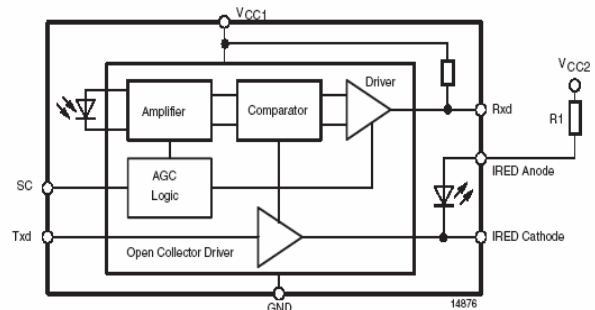

FIGURE 5  
BLOCK DIAGRAM OF TFDU4100

The TFDU4100 is a very low power consumption (1.3mA supply current) surface mount transceiver with a wide operating voltage range between 2.7 to 5.5 V. It has an open collector receiver output with a 20k $\Omega$  internal pull up resistor. It has a built in EMI (Electro Magnetic Interference) protection, such that no external EMI shielding is required.

## 5. Schematic Design

The board schematic has been designed using cadence ORCAD capture $\text{\textcircled{R}}$  tools. The entire board design is divided into five parts for the ease of the design. The first part is the microcontroller schematic design. This part of the schematic carries the ATmega128L microcontroller and the related components. A total of 51 I/O pins have been made available on the board for interfacing. Two external crystal oscillators, 32,768 KHz and 8.0 MHz are connected to the Microcontroller through selection jumpers. A header for JTAG interface is connected to the microcontroller for programming.

The second part of the schematic design consists of the optical transceiver circuits (both optical fiber and infrared). The transmit pin and the receive pin of the transceiver are connected to the UART0 of the ATmega128L controller. Since the microcontroller comes with only two UARTs, UART0 and UART1, the outputs of both the transceivers, i.e. infrared TFDU4100 and optical fiber HFBR5103 have been connected to the same UART0 using selection jumpers.

The third part of the schematic design consists of the RS232 serial port design, the LCD screen interface and the debugging switches and LEDs. The DB9 connector used for serial RS232 communication as discussed in the earlier part of the paper is interfaced with the microcontroller through the MAX202 IC chip. The MAX202 transceiver IC is designed for RS232 communication interface for use in voltage levels less than 12V. The IC is used to level shift the board 5V to  $\pm 12$ V required for RS232 output levels. It allows data rates in excess of 120kbps in standard conditions. It consumes around 8mA of current. The output of the transceiver IC is interfaced through the UART1 pins of the microcontroller.

The LCD module used for the board is the ACM0802C, from AZ Displays, Inc. The LCD module has 8 data pins that are connected to the I/O pins of Port A of the microcontroller. A 10K potentiometer is connected to the display module for providing the LCD contrast.

Switches and LEDs are provided on the board for debugging purposes. There are four switches and four LEDs present on the communication board. Each one of the switch has been connected to a 100K pull up

resistors. Pins 1 and 2 of each of the switch are connected to the ground. The switches are interfaced with the port C of the microcontroller. These switches can be programmed and used along with other modules of the board for different functionalities.

Apart from the four switches, there are four debugging LEDs present on the board. These LEDs can be programmed and used along with different transceiver modules to indicate different states of the board. The LEDs used for the board are small 635nm surface mount of the standard size 1206. The LEDs are connected to Port C (0, 1, 2, and 3) of the microcontroller, each through a 470 $\Omega$  current limiting resistor.

The fourth part of the schematic design is the USB port circuit schematic. The coupling circuit used with the USB miniB connector is shown below.

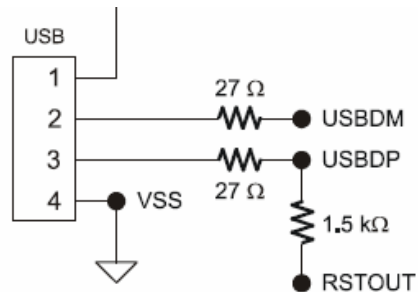

FIGURE 6  
COUPLING CIRCUIT FOR USB

The USBDM and USBDP are the pins of the USB UART transceiver IC (FT232BM) [13]. The FT232BM comes in a 32 pin surface mount package as shown below. Two LEDs are connected to the TXLED and RXLED pins of the Transceiver IC. These LEDs indicate transmit and receive activity of the transceiver IC. An external 6MHz crystal oscillator is connected to IC.

The fifth and the last part of the schematic design is the important power circuit schematic. The power circuit has been designed keeping in mind the voltage ratings and the different voltage ranges within which all the components present on the board work reliably. The board can be connected to a voltage source ranging between 9V to 15V DC. The voltage coming into the board has to be brought down to an operating range of regulated 5V DC for the board to work. A bridge rectifier circuit followed by a 5V DC regulator has been used for this purpose. The bridge rectifier is a standard DF10S surface mount IC chip, with high current and high surge current capabilities. The voltage regulator used is a standard 78M05A, positive regulator. It employs internal current limiting, thermal shutdown and safe area protection, making it less prone to failure.

## 6. Theoretical Analysis

The following table shows the different modules present on the communication board along with their rated maximum speeds for communication.

Module ( device )	Max. Device throughput	Throughput via UART
HFBR 5103 (Optical )	100 Mbps	2.5 Mbps*
TFDU4100 (Infrared )	0.115 Mbps	0.115 Mbps*
USB	480 Mbps	2.5 Mbps*
RS232	–	0.120Mbps*

TABLE 1  
DEVICE THROUGHPUT

\* The UART throughput has been calculated using the crystal oscillator frequency of 20.0 MHz and bit error of 0.0 %.  
\*\* Maximum rate allowed with MAX202 driver IC.

As shown in the table above the USB has the highest throughput out of the rest of the communication modules used in the board, however the throughput reduces to only 2.5 Mbps via the UART of the microcontroller. If the used oscillator frequency of the microcontroller is further reduced the throughput via the UART will also reduce. The slowest communication module in the board is the infrared transceiver, with a throughput of 115.2 Kbps. Transmission of data from one module to another through the microcontroller will be completely limited by the UART throughput. If we consider an example of data communication from PC through the RS232 port to the optical fiber transceiver, via the UART of the microcontroller, the data rate will be limited to a maximum of just 2.5Mbps as compared to the maximum rated value of 100 Mbps for the optical transceiver. The same data communication via the I/O pins of the microcontroller will however be more and will depend upon the software (programming efficiency), and the oscillator frequency of the microcontroller.

## 7. Conclusion and future work

Engineers who have knowledge of embedded systems and optical communications will be in high demand. Unfortunately, there are few affordable lab exercises or

development environments available for classroom use, so students often do not learn about these technologies during hands-on lab assignments. The communications hub or simply data communication educational board provides the student with an opportunity to learn and at the same time have hands on experience with some of the areas in infrared and fiber optic communications that are being used in the industry. Test codes and sample codes will be provided along with the board for the students to test the various data communication modules present on the board. The students can modify the sample codes or develop their own codes to work with the board. Future work includes developing course material to be taught in embedded systems or communication courses in universities using the communication educational board and developing lab exercises for the students to work on the board in the labs.

## 8. References

- [1]. Behnam Kamali, "Development of an undergraduate structured laboratory to support classical and new base technology experiments in communications," *IEEE Transactions on Education*, v 37, n 1, Feb, 1994, pp. 97-105.
- [2]. Behnam Kamali, "A Three-Level Structured Laboratory to Support Traditional and New-Base Technology Experiments in Communications," NSF Award No. 9153146, University of Texas at San Antonio, May 15 1991 to Oct 31 1993.
- [3]. Levent Sevgi, "EMC and BEM engineering education: Physics-based modeling, hands-on training and challenges," *IEEE Antennas and Propagation Magazine*, v 45, n 2, April, 2003, p 114-119.
- [4]. V.E DeBrunner, L.S. DeBrunner, S. Radhakrishnan, Khan Kamal, "The telecomputing laboratory: A multipurpose laboratory," *IEEE Transactions on Education*, v 44, n 4, November 2001, pp. 302-310.
- [5]. Michael Munoz, Susan Garrod, "In process development of an advanced undergraduate communications laboratory," *Proceedings of the 1997 Frontiers in Education Conference*, v2, 1997. Part 2 (of 3), Nov 5-8 1997.
- [6]. Ali Behagi, "Development of a wireless and satellite communication laboratory at Penn State Harrisburg," *Proceedings of the 1997 ASEE Annual Conference*, Jun 15-18 1997, Milwaukee, WI, USA, 5p.
- [7]. E. Bertran, F. Tarres, G. Montoro, "Experimental course on digital communications," *Proceedings of the IEEE International Conference on Electronics, Circuits, and Systems*, v 3, Sep 7-Sep 10 1998, p 321-324.
- [8]. William D. Lane, "Textbook principles to communications hardware: Making it work," *Proceedings of the 1996 Frontiers in Education Conference*, v 3, Nov 6-9 1996, p 1504-1507.
- [9]. James M. Conrad, Sami Lasassmeh, Ishfan Wakil, and Benjamin Levine, "Teaching Optical Communications Concepts in Embedded Systems Courses," *Proceedings of the 2005 Frontiers in Education Conference*, Indianapolis, IN, October 2005.
- [10]. ATmega128L: [http://www.atmel.com/dyn/resources/prod\\_documents/doc2467.pdf](http://www.atmel.com/dyn/resources/prod_documents/doc2467.pdf)
- [11]. HFBR-5103: <http://www.home.agilent.com/semiconductors>
- [12]. TFDU4100: <http://www.vishay.com/docs/82514/82514.pdf>
- [13]. FT232BM: <http://www.ftdichip.com/Documents/DataSheets/ds232b18.pdf>