

ECGR-6185  
Advanced Embedded Systems

---

**ZI GBEE**  
**802. 15. 4**



**University of North Carolina-Charlotte**

---

*Ø Chaitanya Misal*  
*Ø Vamsee Krishna*

# WPAN

§A **personal area network** (PAN) is a computer network used for communication among computer devices (including telephones and personal digital assistants) close to one person

§Reach: *A few meters*

§Use: *Intrapersonal communication in devices.*

*Connecting to a higher level network and the Internet.*

§A **wireless PAN** consists of a dynamic group of less than 255 devices that communicate within about a 33-foot range

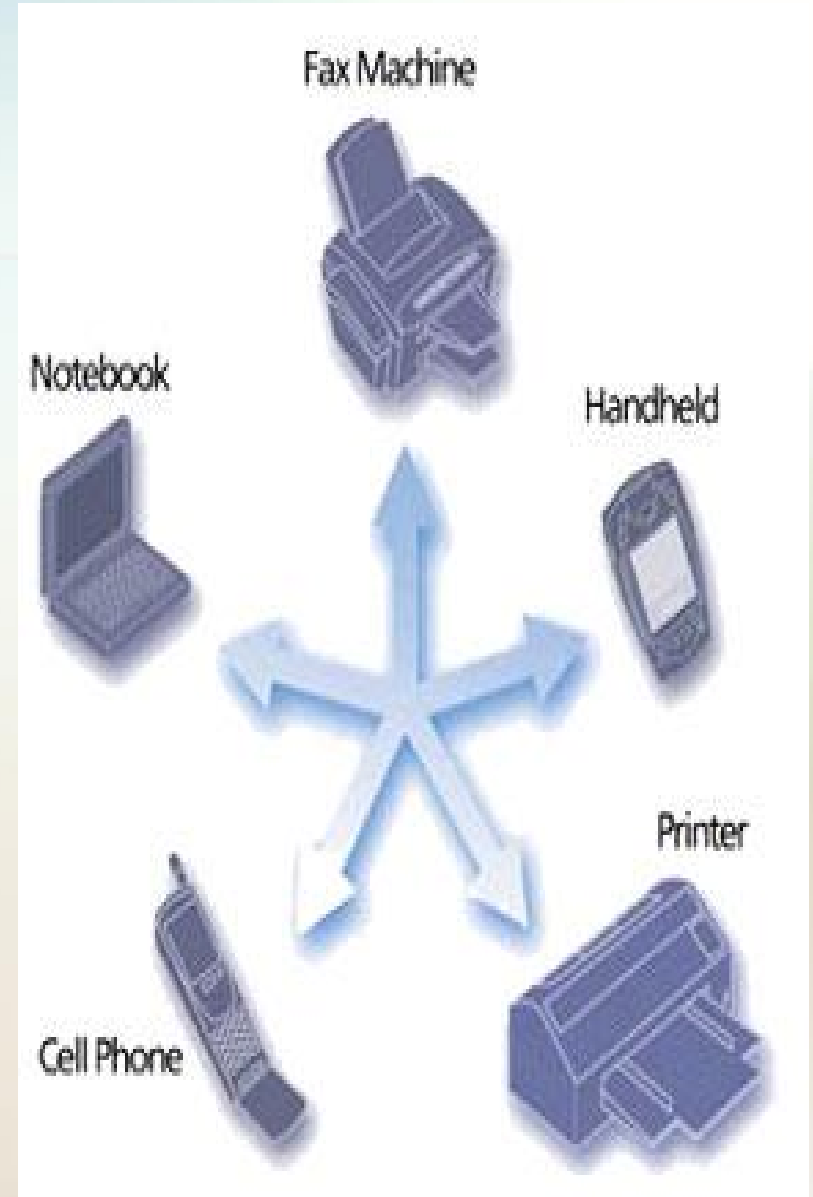

# 802.15

---

- § **IEEE 802.15 is the 15th working group of the IEEE 802**
- § **Specializes in Wireless PAN (Personal Area Network)**
- § **It includes four task groups (numbered from 1 to 4)**

# IEEE 802 LAN/MAN Standards Committee

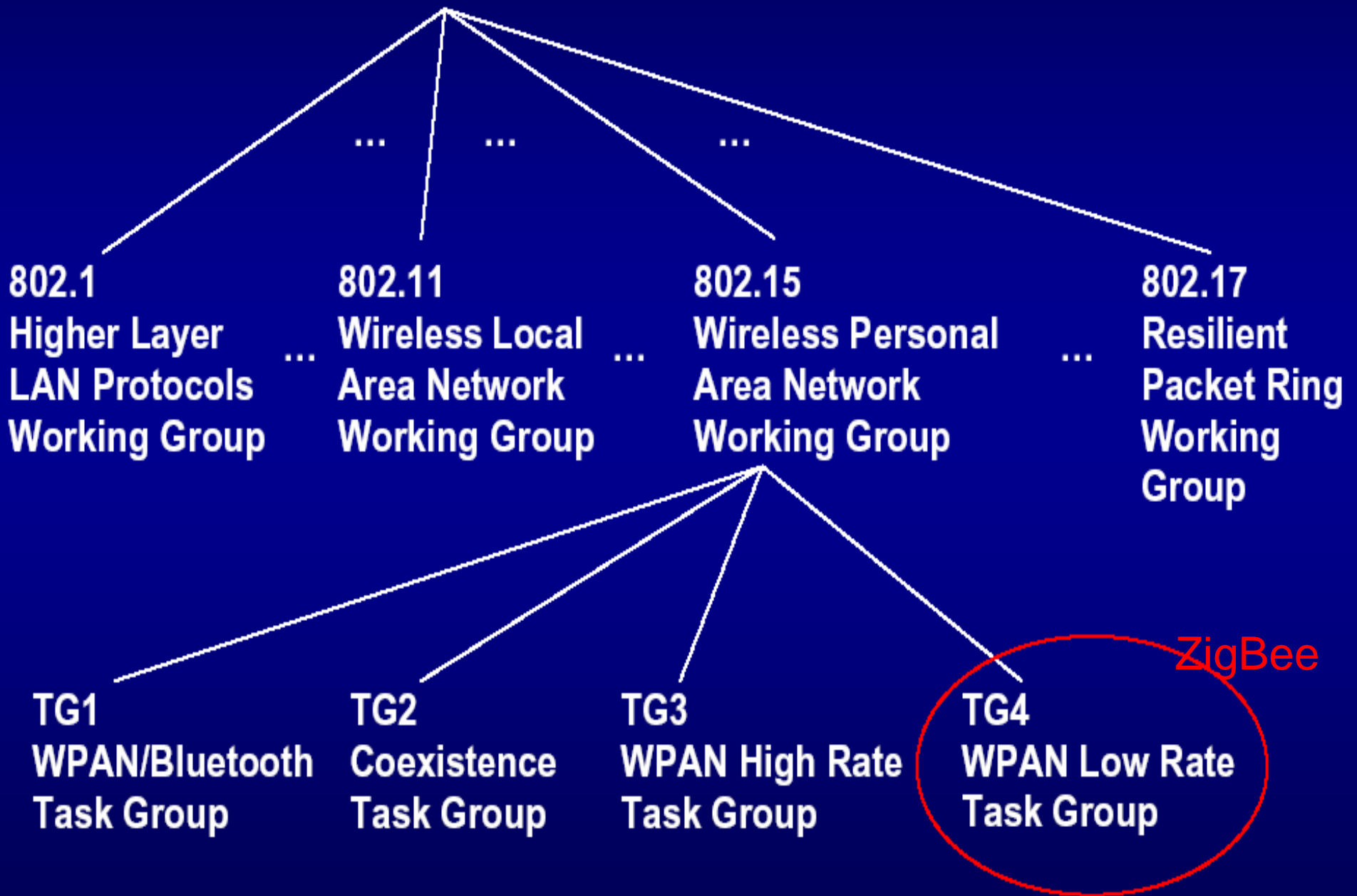

- **IEEE 802.15.4 - Standard released in May 2003 for LR-WPAN**

- **Zigbee - set of high level communication protocols based upon the specification produced by 802.15.4**

- **The ZigBee Alliance is an association of companies working together to enable reliable, cost-effective, low-power, wirelessly networked, monitoring and control products based on an open global standard.**



# Standards Expectations

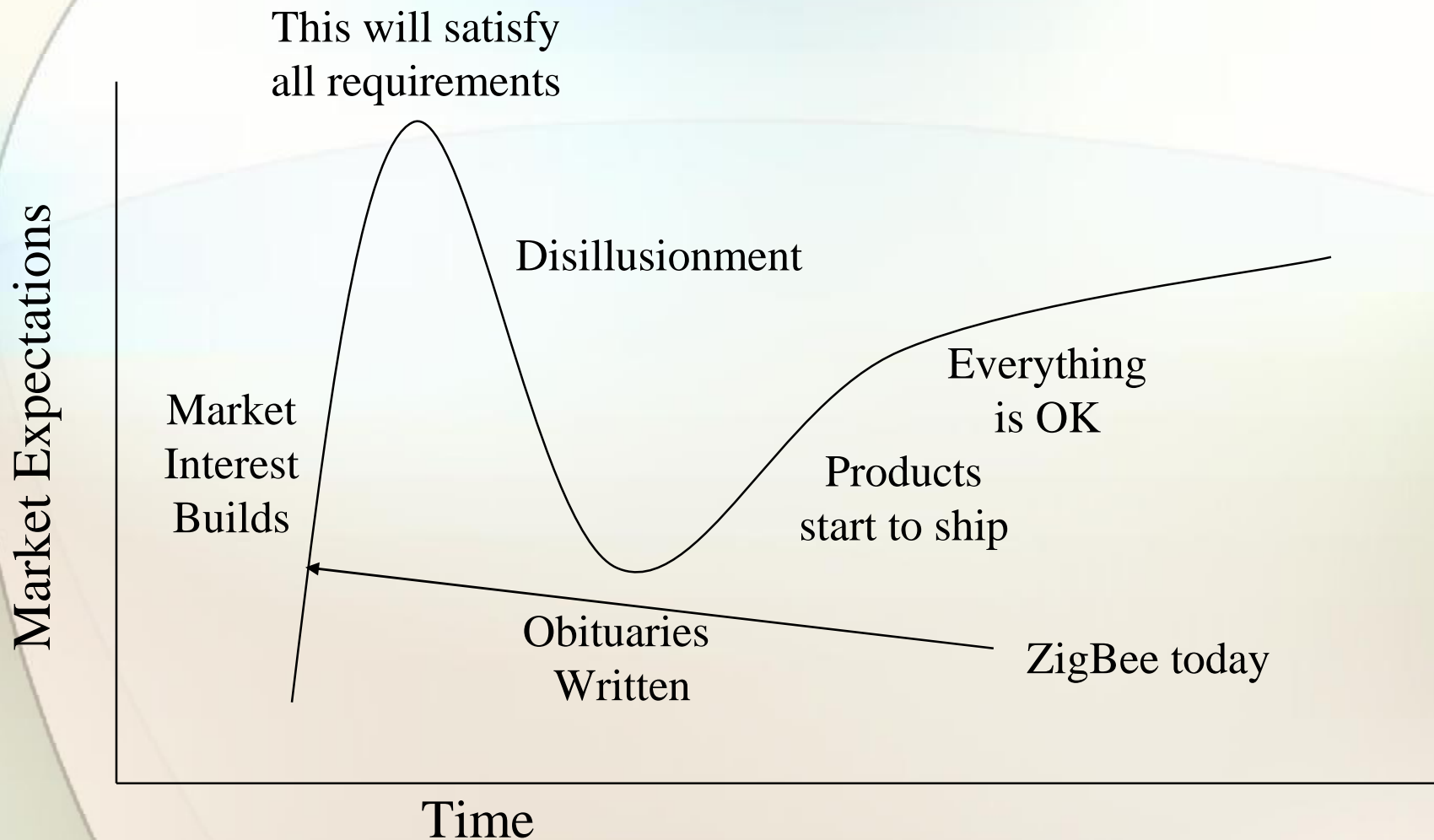

# ZigBee Wireless Markets and Applications

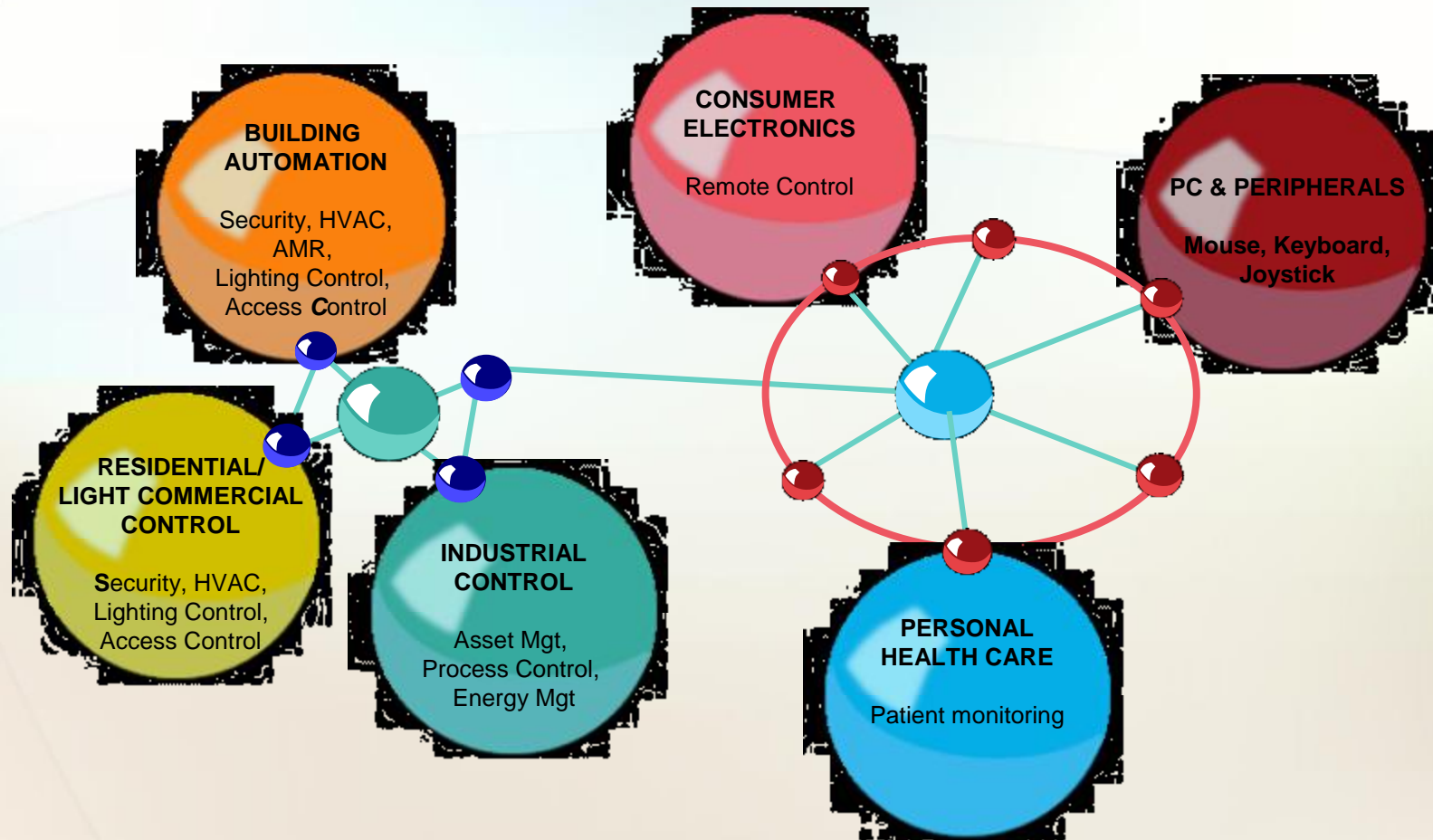

# ZigBee Network



Chaitanya Misal, Vamsee Krishna

# Network Topology Models

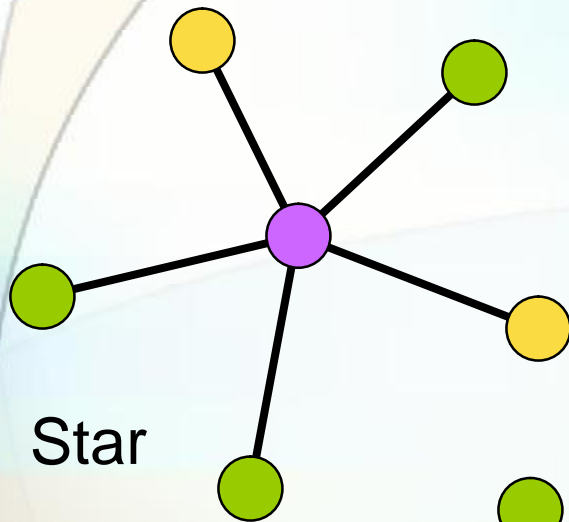

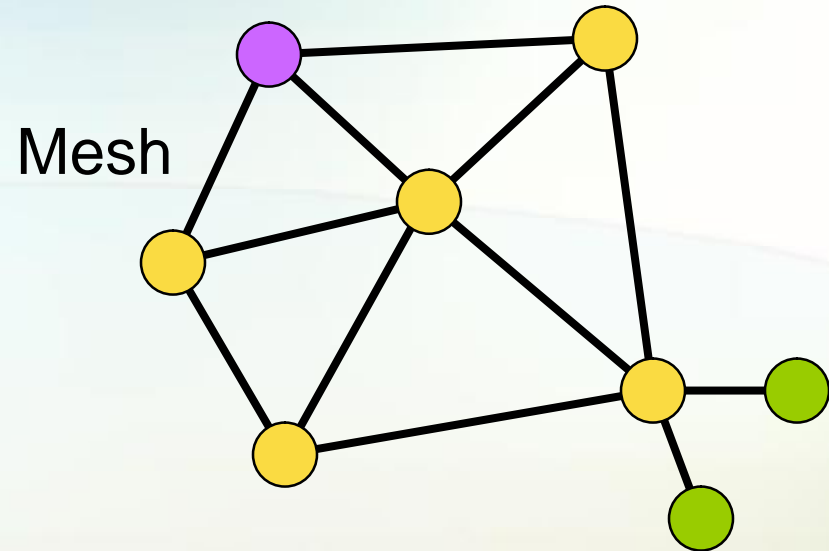

Star

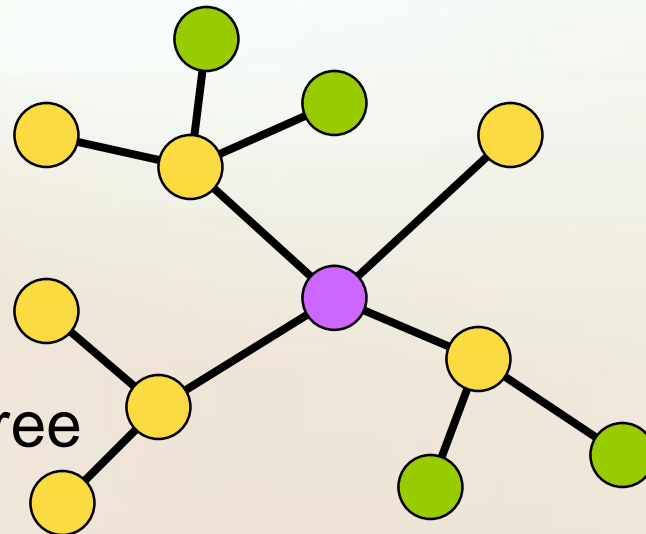

Mesh



Cluster Tree

-  PAN coordinator (PANC)
-  Full Function Device (FFD,Router)
-  Reduced Function Device (RFD)

# Wireless networking Basics

---

## **Network Scan**

*Device scans the 16 channels to determine the best channel to occupy.*

## **Creating/Joining a PAN**

*Device can create a network (coordinator) on a free channel or join an existing network*

## **Device Discovery**

*Device queries the network to discover the identity of devices on active channels*

## **Service Discovery**

*Device scans for supported services on devices within the network*

## **Binding**

*Devices communicate via command/control messaging*

# Network Pieces –PAN Coordinator

- **PAN Coordinator**

- **“owns” the network**
  - Starts it
  - Allows other devices to join it
  - Provides binding and address-table services
  - Saves messages until they can be delivered
  - And more... could also have i/o capability
- **A “full-function device” – FFD**
- **Mains powered**

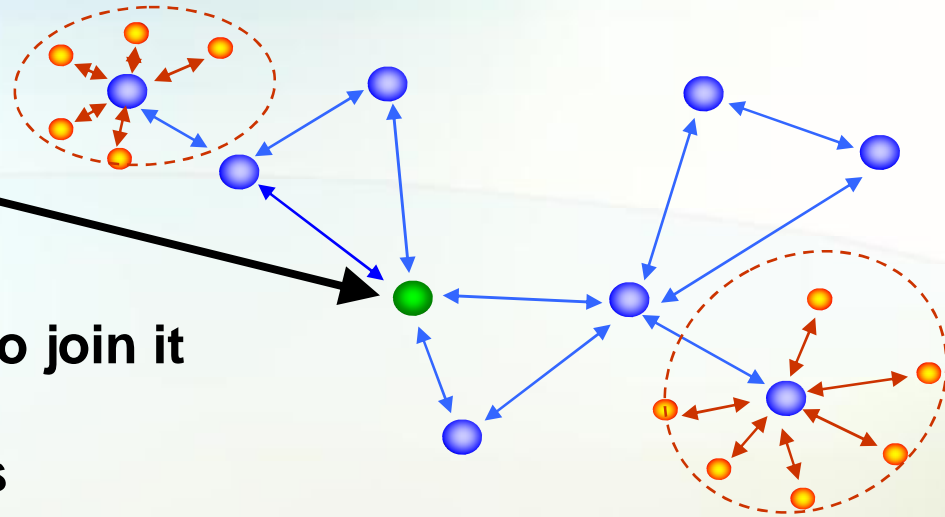

# Network Pieces - Router

- **Routers**
  - **Routes messages**
  - **Does not own or start network**
    - Scans to find a network to join
      - Given a block of addresses to assign
  - A “full-function device” – FFD
  - Mains powered depending on topology
  - Could also have i/o capability

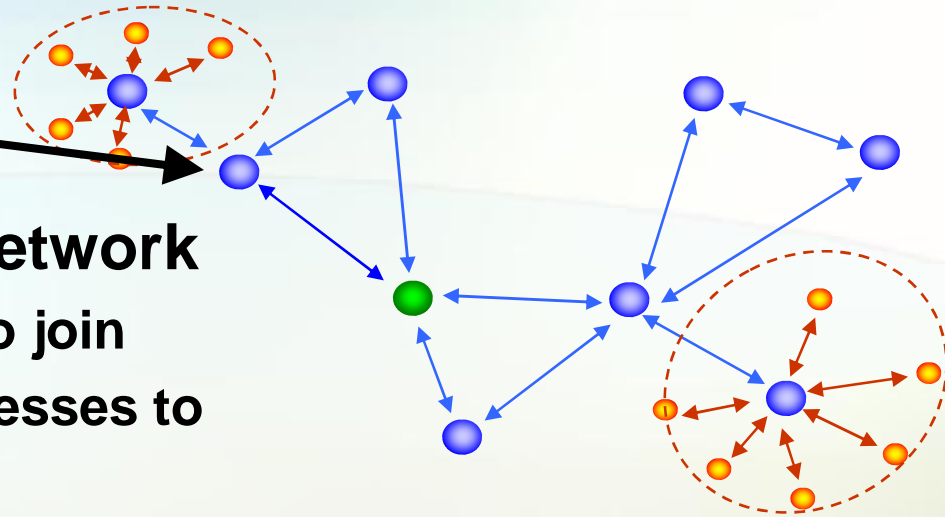

# Network Pieces – End Device

- **End Device**

- **Communicates with a single device**

- **Does not own or start network**

- **Scans to find a network to join**

- **Can be an FFD or RFD (reduced function device)**

- **Usually battery powered**

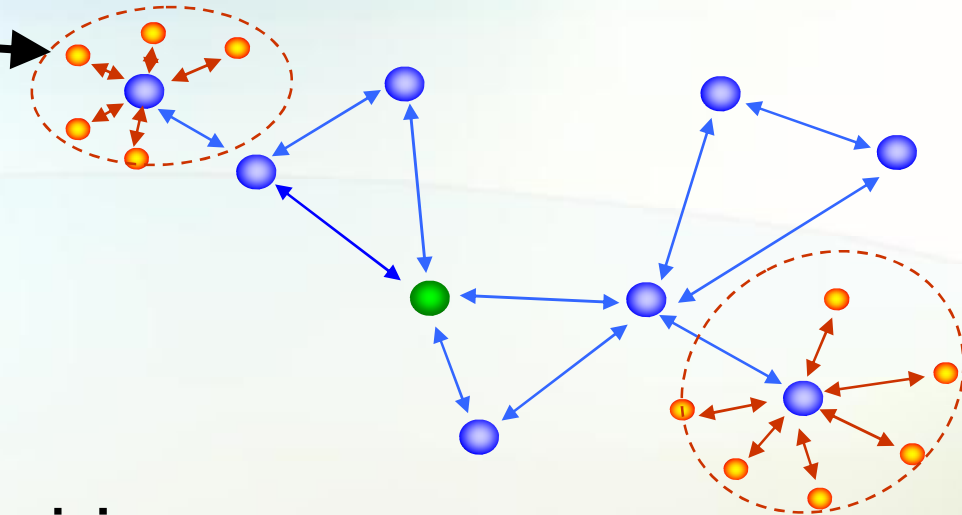

# ZigBee is Mesh Networking

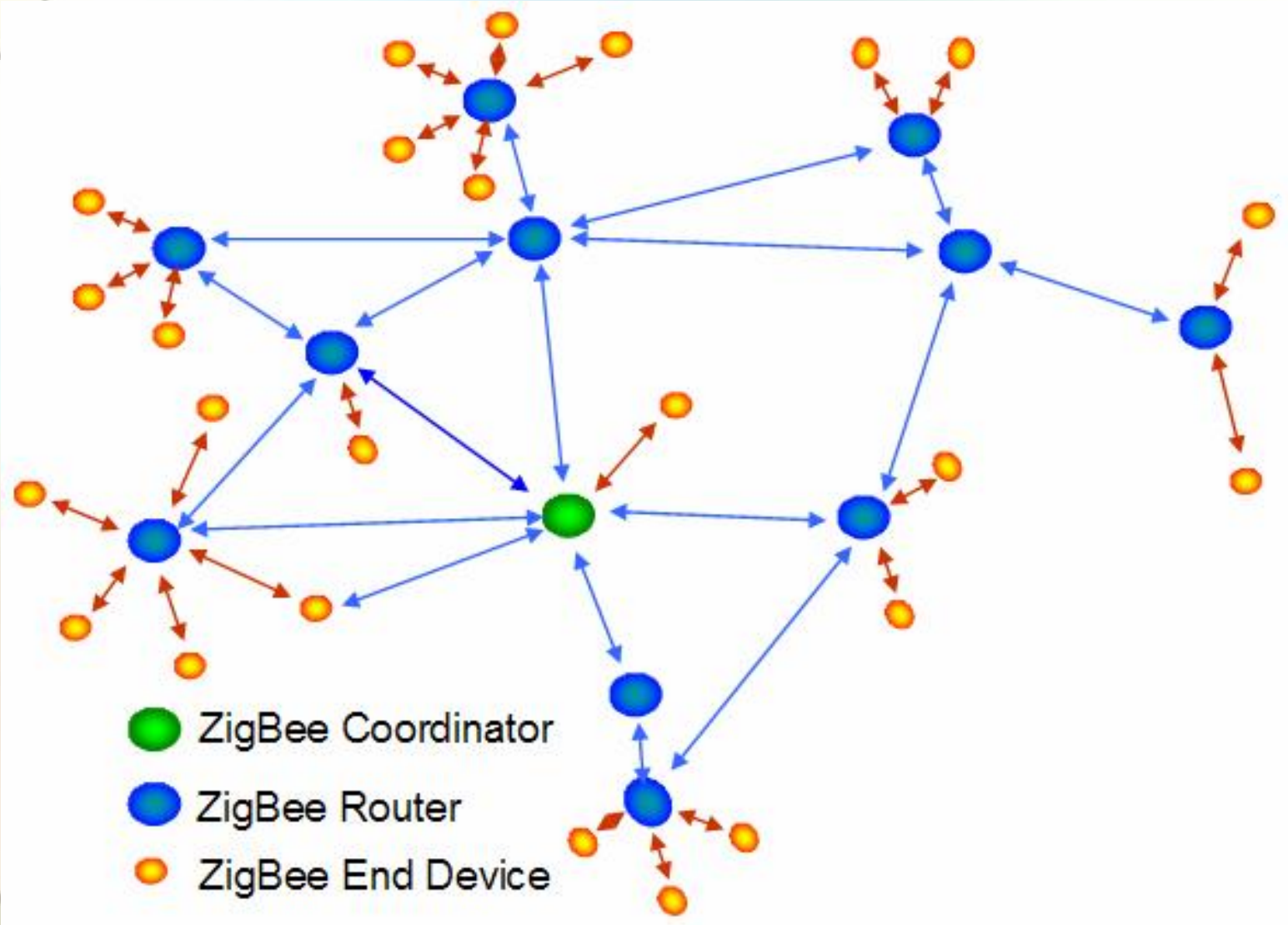

# Traffic types

---

- **Periodic data**
  - Application defined rate (e.g. **sensing temperature**)
- **Intermittent data**
  - Application/external stimulus defined rate (e.g. **light switch**)
- **Repetitive low latency data**
  - Allocation of time slots (e.g. **mouse**)

# IEEE 802.15.4

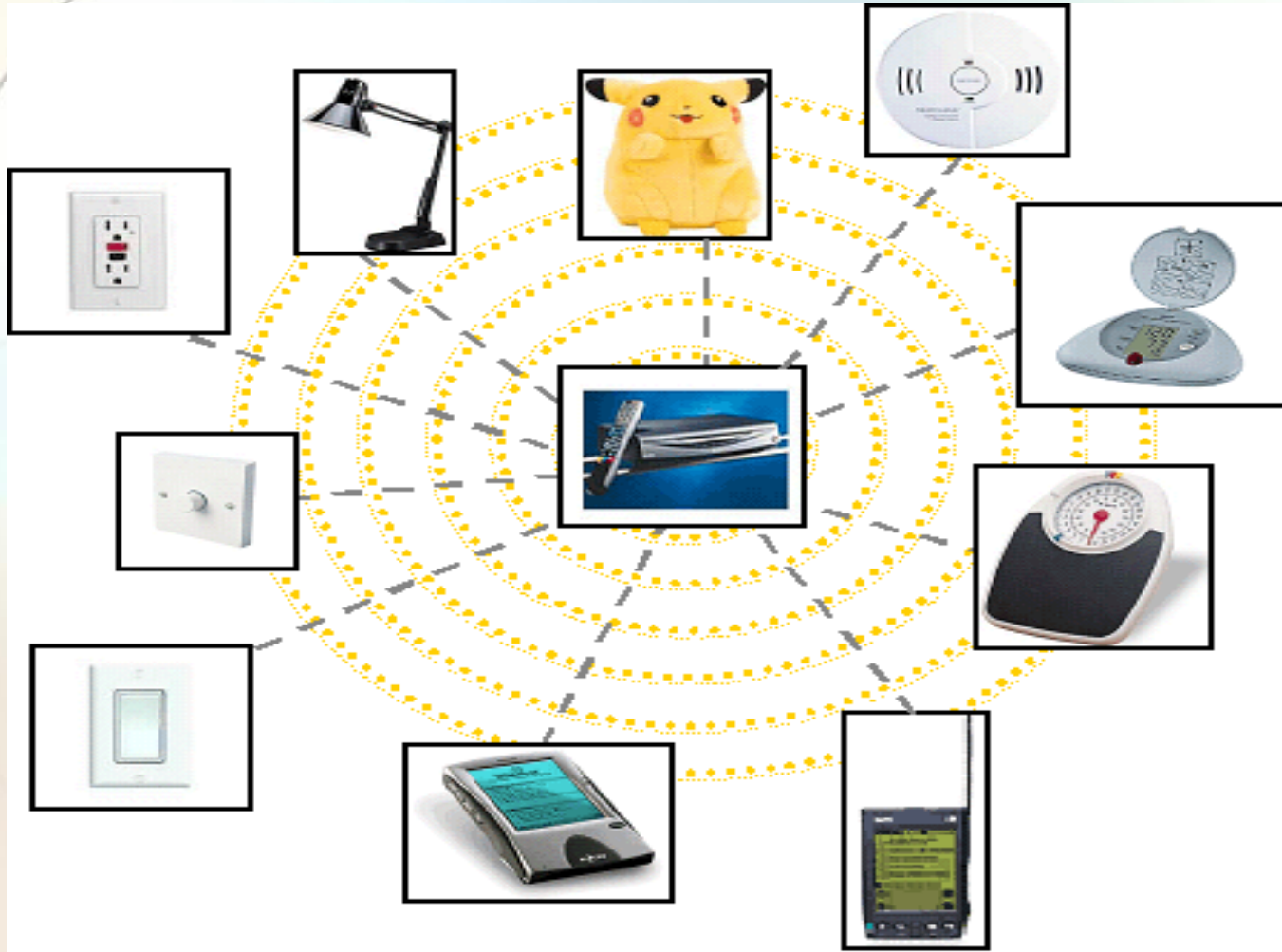

# ZigBee Alliance - IEEE - Customer Relationship

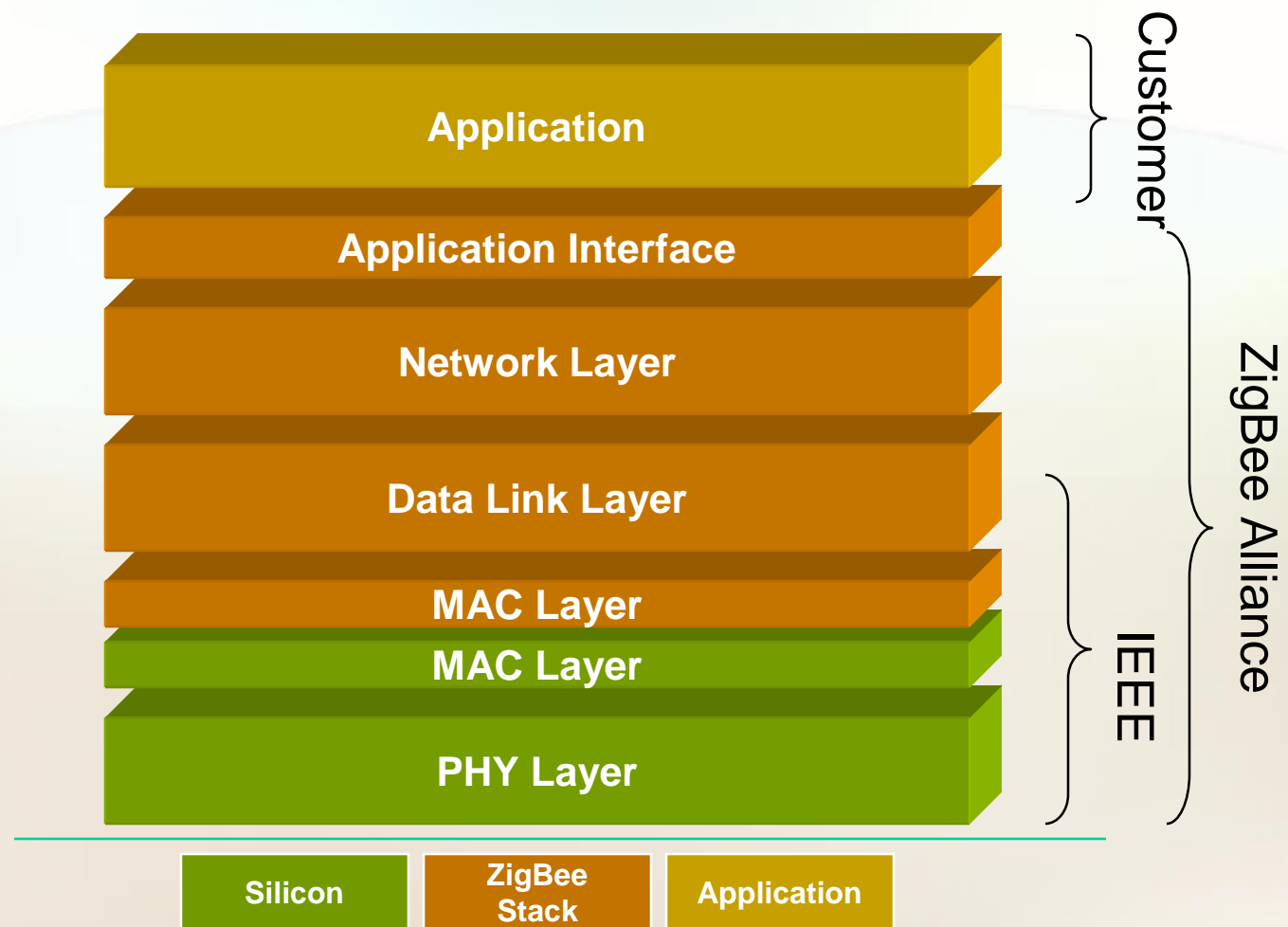

# 802.15.4 Architecture: Physical Layer

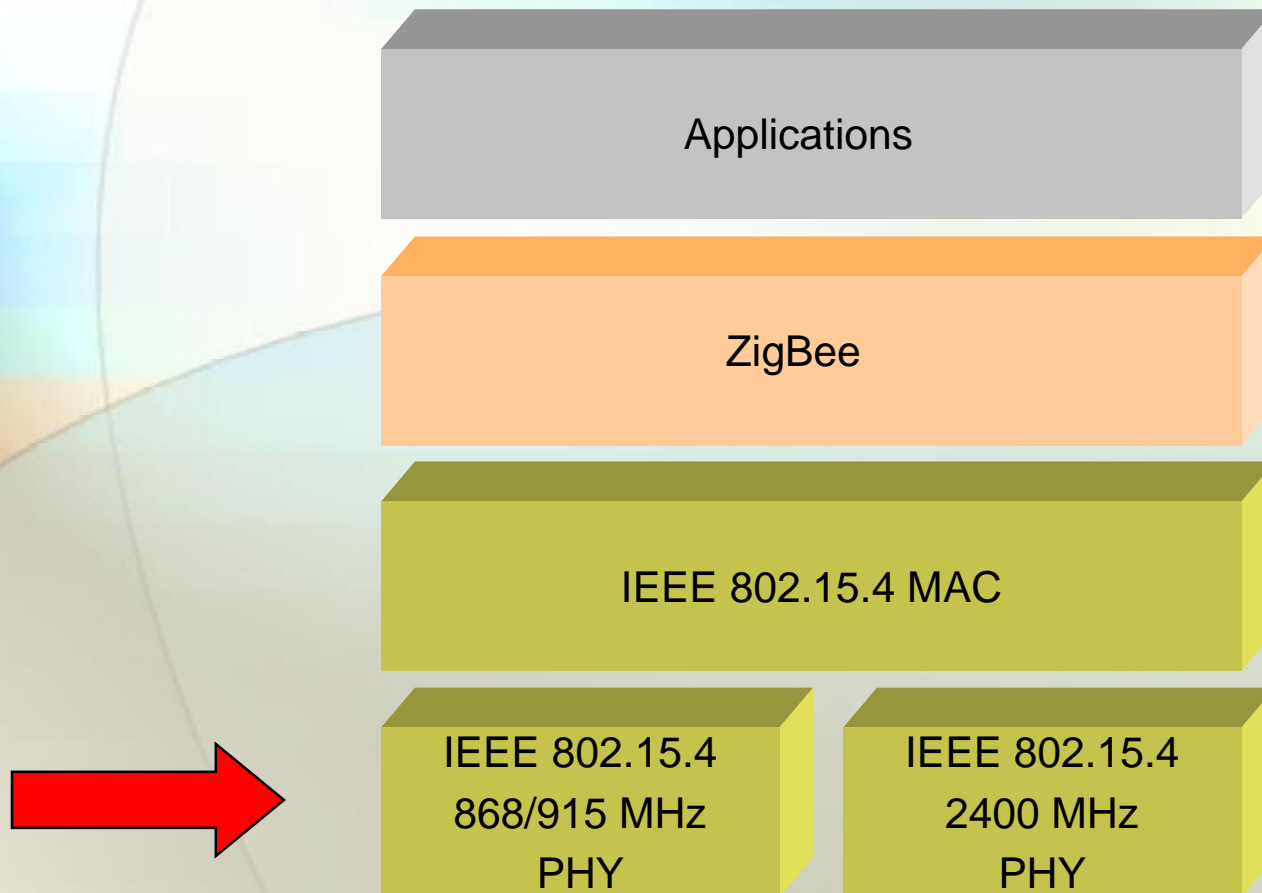

# Physical Layer functionalities:

---

- Ø Activation and deactivation of the radio transceiver
- Ø Energy detection within the current channel
- Ø Link quality indication for received packets
- Ø Clear channel assessment for CSMA-CA
- Ø Channel frequency selection
- Ø Data transmission and reception

## ZigBee specifies two Physical media:

---

- Ø 868 MHz/915 MHz direct sequence spread spectrum (DSSS) PHY (11 channels)
  - 1 channel (20Kb/s) in European 868MHz band
  - 10 channels (40Kb/s) in 915 (902-928)MHz ISM band
- Ø 2450 MHz direct sequence spread spectrum (DSSS) PHY (16 channels)
  - 16 channels (250Kb/s) in 2.4GHz band

# IEEE 802.15.4 Physical Layer

- Operates in unlicensed ISM bands:

**868MHz/  
915MHz  
PHY**

Channel 0

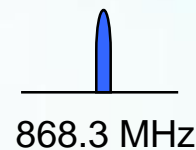

Channels 1-10

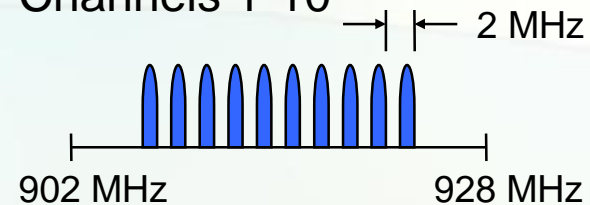

**2.4 GHz  
PHY**

Channels 11-26



# IEEE 802.15.4 PHY Overview Packet Structure

## PHY Packet Fields

- Preamble (32 bits) – synchronization
- Start of Packet Delimiter (8 bits)
- PHY Header (8 bits) – PSDU length
- PSDU (0 to 1016 bits) – Data field

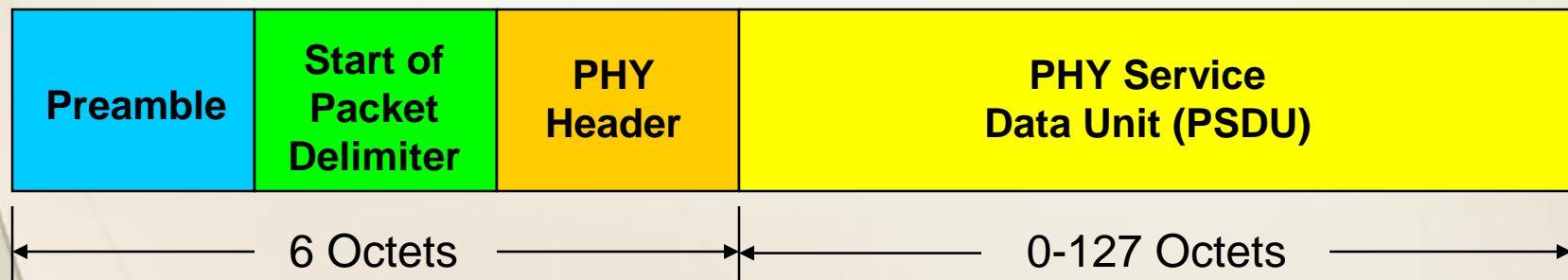

# 802.15.4 Architecture: MAC layer

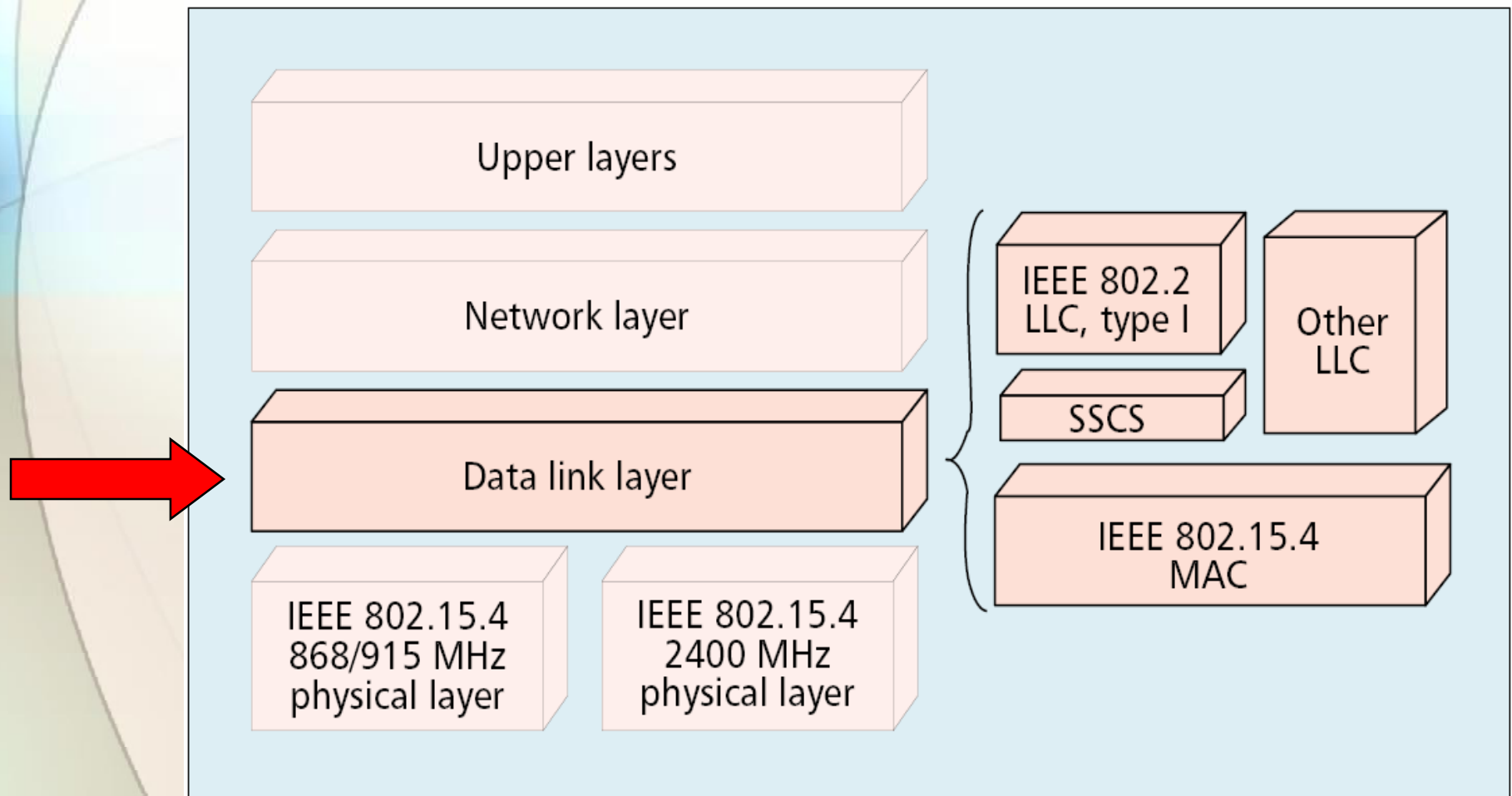

# IEEE 802.15.4 MAC Overview

## Design Drivers

---

- Ø Extremely low cost
- Ø Ease of implementation
- Ø Reliable data transfer
- Ø Short range operation
- Ø Very low power consumption

**Simple but flexible protocol !**

# IEEE 802.15.4 MAC Overview

## General Frame Structure

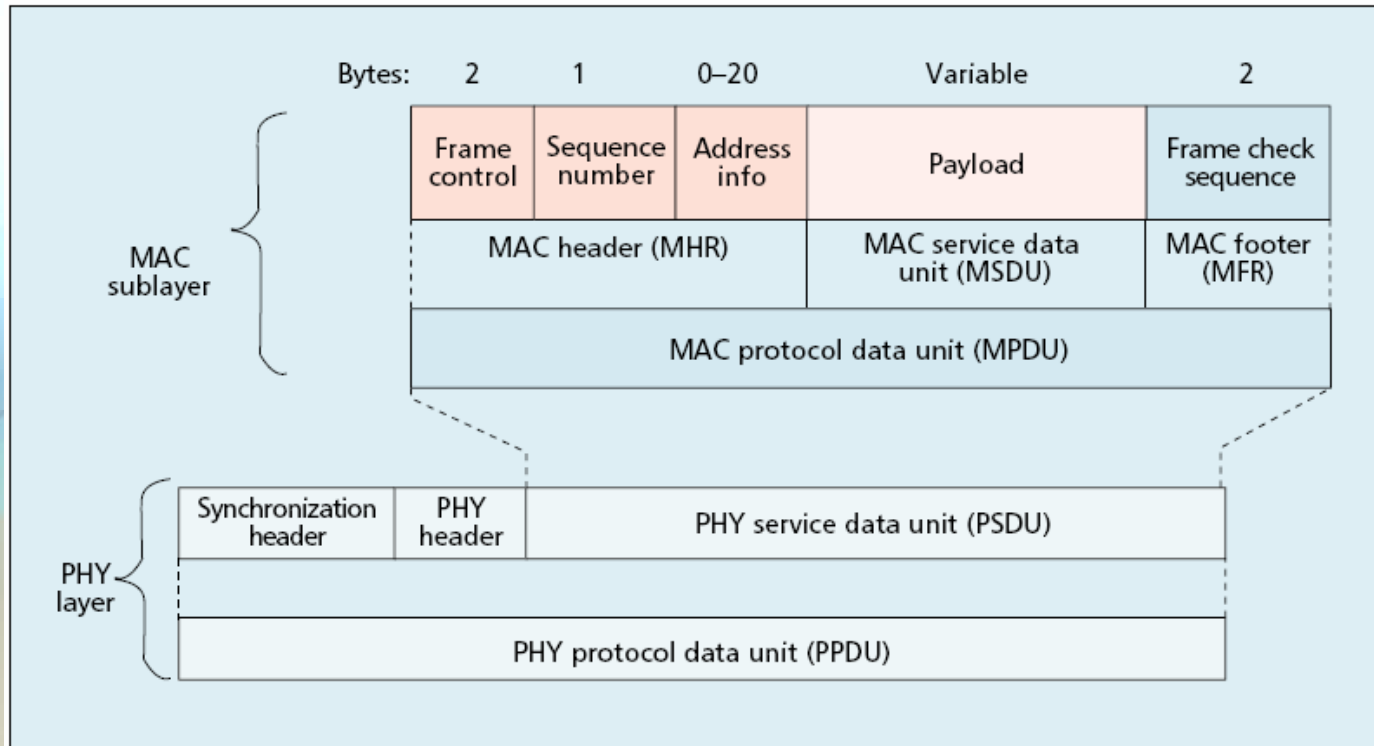

4 Types of MAC Frames:

- Ø Data Frame
- Ø Beacon Frame
- Ø Acknowledgment Frame
- Ø MAC Command Frame

# Data Transfer Model

## Data transferred from device to coordinator

- In a beacon-enabled network, device finds the beacon to synchronize to the super-frame structure. Then using slotted CSMA/CA to transmit its data.
- In a non beacon-enabled network, device simply transmits its data using un-slotted CSMA/CA

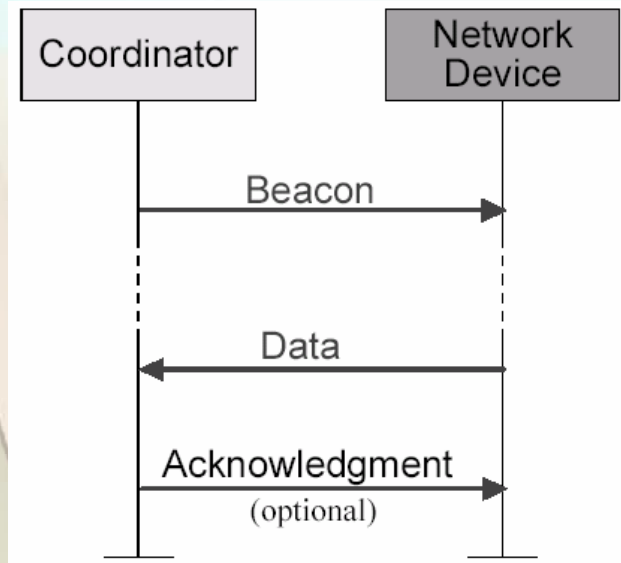

Communication to a coordinator  
In a **beacon-enabled** network

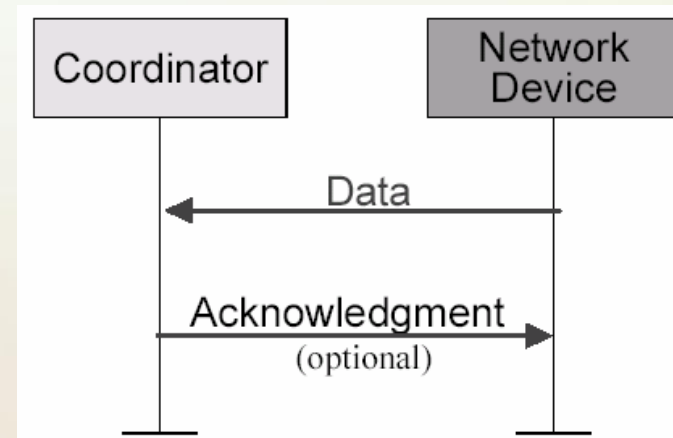

Communication to a coordinator  
In a **non beacon-enabled** network

# Data Transfer Model

- Data transferred from coordinator to device
  - In a beacon-enabled network, the coordinator indicates in the beacon that "**data is pending.**"
  - Device periodically listens to the beacon and transmits a **MAC command request** using slotted CSMA/CA if necessary.

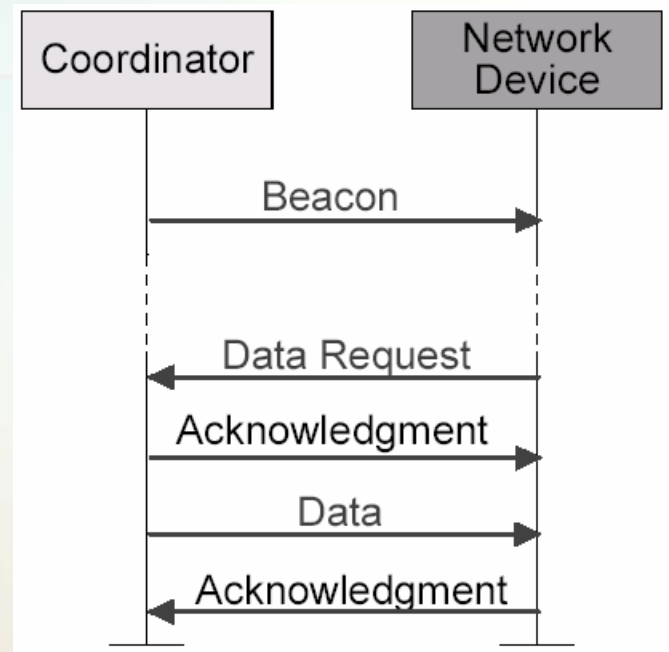

Communication from a coordinator  
In a **beacon-enabled** network

# Superframe: CSMA-CA + TDMA

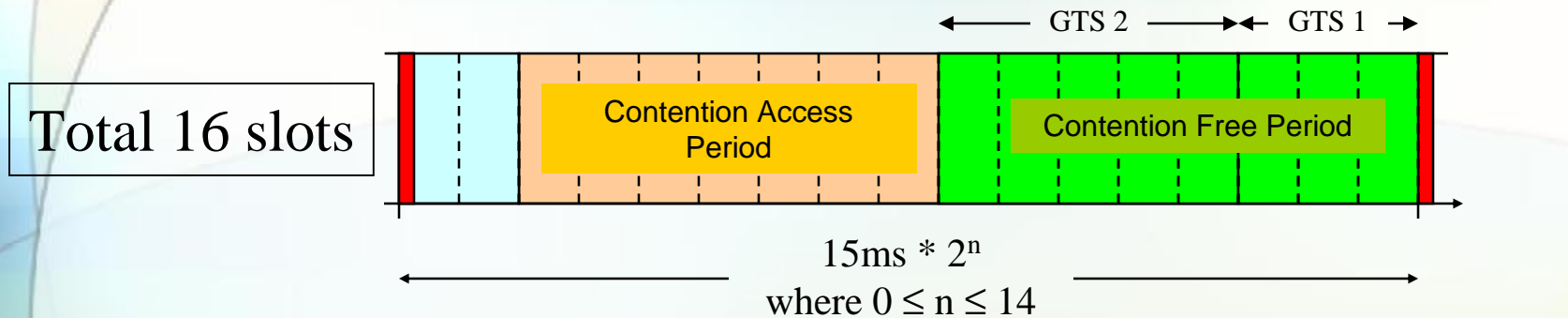

Network beacon



Transmitted by network coordinator. Contains network information, frame structure and notification of pending node messages.

Beacon extension period



Space reserved for beacon growth due to pending node messages

Contention period



Access by any node using CSMA-CA

Guaranteed Time Slot



Reserved for nodes requiring guaranteed bandwidth [ $n = 0$ ].

up to 7 GTSEs

# 802.15.4 Architecture

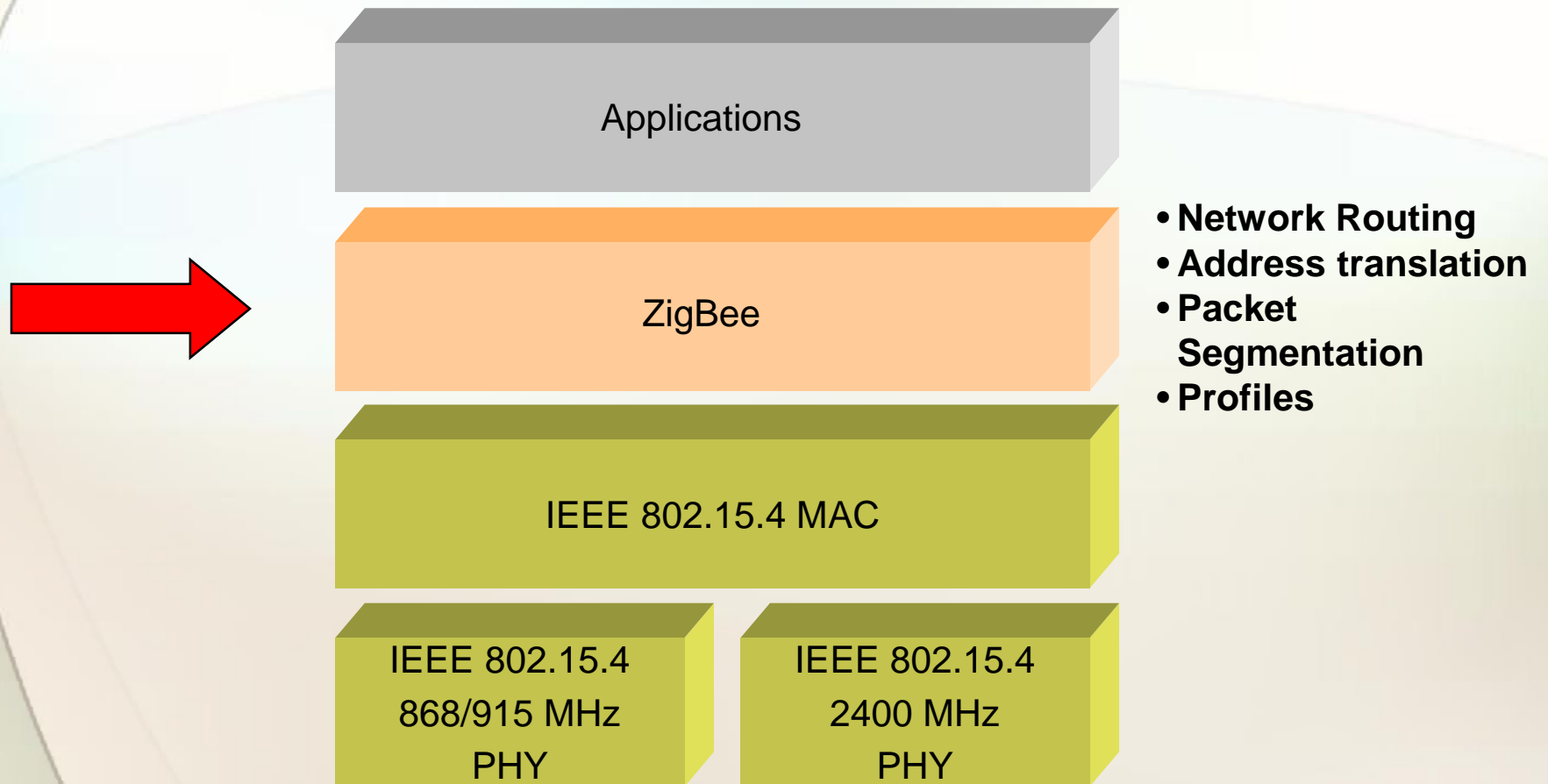

# ZigBee Stack Architecture :

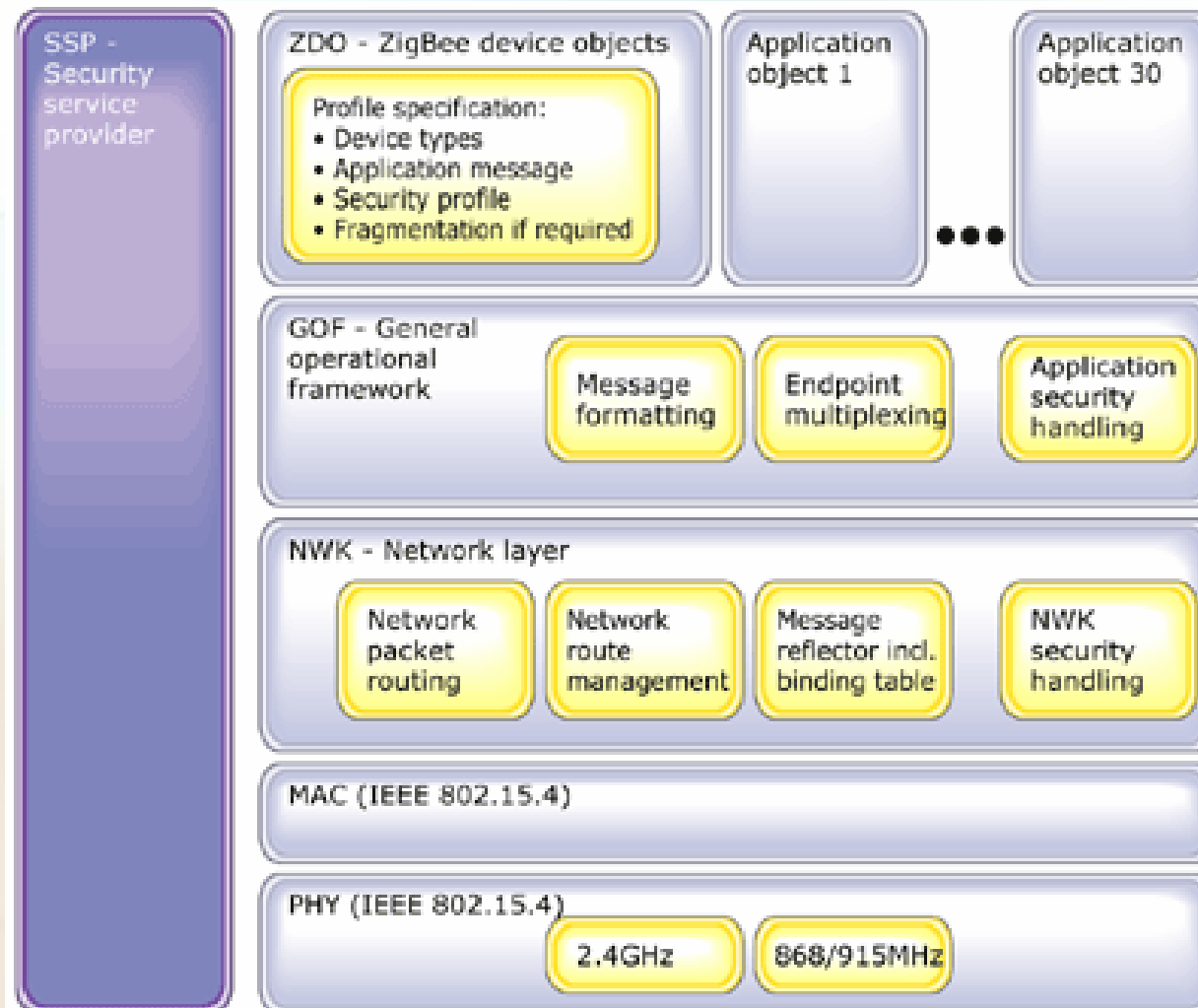

# Comparison with peer technologies!

Feature(s)	IEEE 802.11b	Bluetooth	ZigBee
Power Profile	Hours	Days	Years
Complexity	Very Complex	Complex	Simple
Nodes/Master	32	7	64000
Latency	Enumeration upto 3 seconds	Enumeration upto 10 seconds	Enumeration 30ms
Range	100 m	10m	70m-300m
Extendability	Roaming possible	No	YES
Data Rate	11Mbps	1Mbps	250Kbps
Security	Authentication Service Set ID (SSID)	64 bit, 128 bit	128 bit AES and Application Layer user defined

# ZigBee vs Bluetooth

**Competition or  
Complementary?**

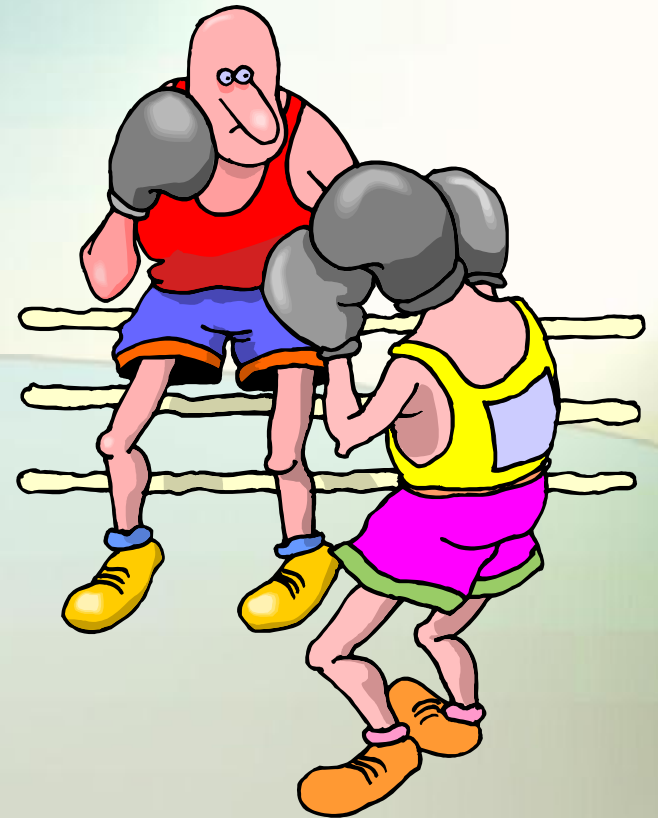

# Bluetooth is Best

For :

- Ad-hoc networks between capable devices
- Handsfree audio
- Screen graphics, pictures...
- File transfer

# But ZigBee is Better

If :

- The Network is static
- Lots of devices
- Infrequently used
- Small Data Packets



# Air Interface:

---

**ZigBee**

**DSSS**

**11 chips/ symbol**

**62.5 K symbols/s**

**4 Bits/ symbol**

**Peak Information Rate**

**~128 Kbit/second**

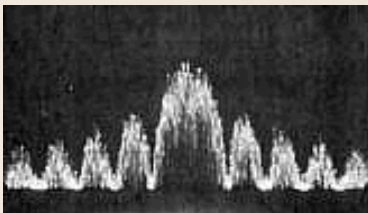

**Bluetooth**

**FHSS**

**1 M Symbol / second**

**Peak Information Rate**

**~720 Kbit/second**



# Timing Considerations

---

## ZigBee:

- New slave enumeration = 30ms typically
- Sleeping slave changing to active = 15ms typically
- Active slave channel access time = 15ms typically

## Bluetooth:

- New slave enumeration = >3s
- Sleeping slave changing to active = 3s typically
- Active slave channel access time = 2ms typically

**ZigBee protocol is optimized for timing critical applications**

# Initial Enumeration

**ZigBee**  
Coordinator

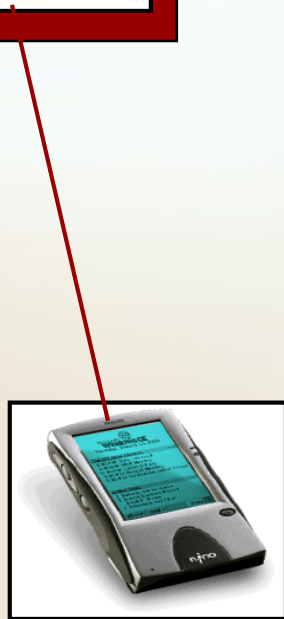
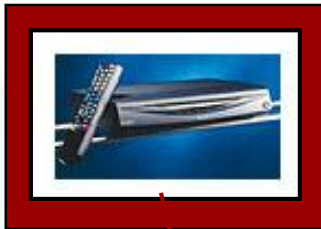

**Bluetooth**  
Coordinator

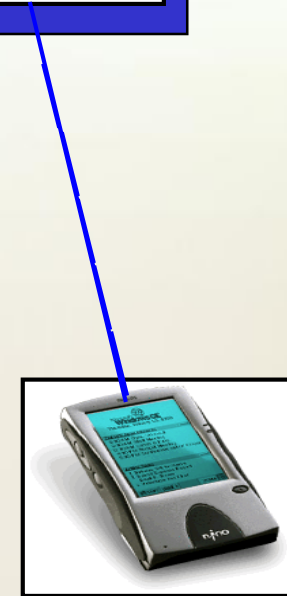

# Power Considerations

---

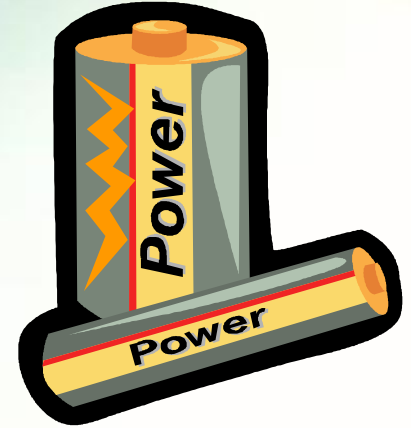

## ZigBee

- **2+ years from 'normal' batteries**
- **Designed to optimise slave power requirements**

Application example of a light switch with respect to latency and power consumption .....

## Bluetooth

- **Power model as a mobile phone (regular charging)**
- **Designed to maximise ad-hoc functionality**

# Some Interesting Applications of **ZigBee**

---

- Using the power of the mesh to automate a manual process
  - ∅ *Rental Car Return Automation\**
- Long life battery powered sensing
  - ∅ *Wireless Termite Detection\**

*\*From Software Technologies Group*

# Automated Rental Car Return\*



Car Rental

File Settings

VIN	License	Description	Odometer	Fuel	Collision	Engine
WMWRC33412TC34910	MINI 723	2004 Mini Cooper, Black	57829	3/4	Check	Ok
WBAEH73455B191834	7Z 2715	2005 BMW 645Ci, Metallic Blue	87410	Empty	Ok	Check
WP0ZZ99Z2S630474	SAB 1973	2003 Porsche 911, Silver	38579	1/2	Ok	Ok

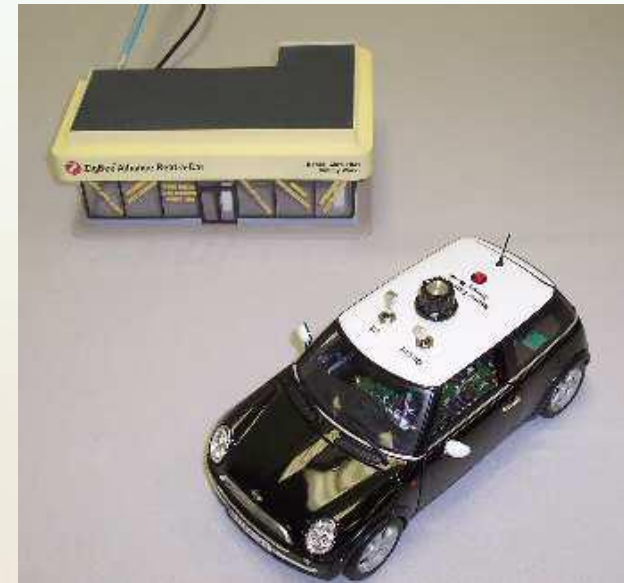
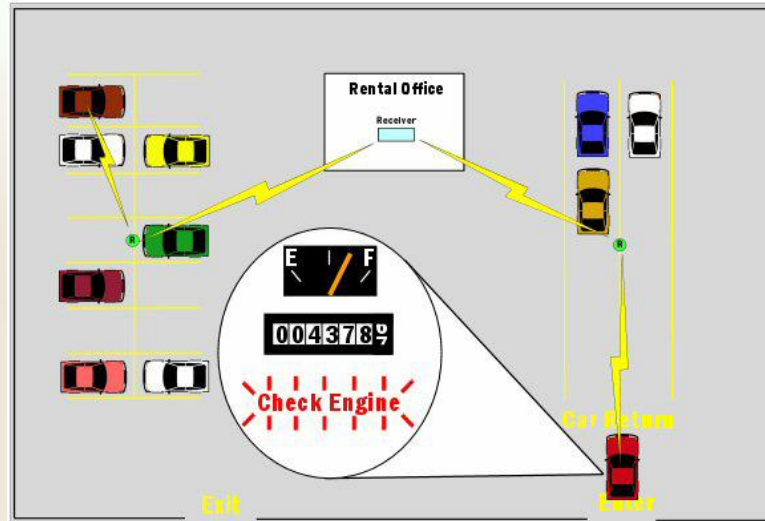

\*From Software Technologies Group  
Chaitanya Misal, Vamsee Krishna

# Termite Detection\*

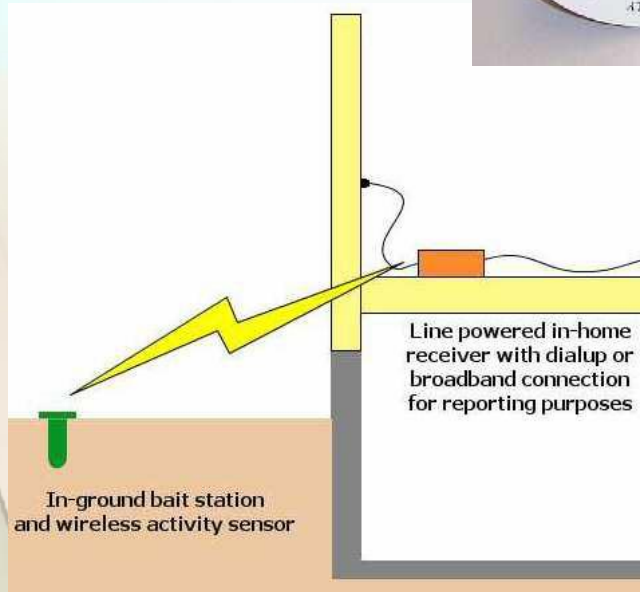

\*From Software Technologies Group  
Chaitanya Misal, Vamsee Krishna

# 802.15.4/ZigBee Products



Control4 Home Automation System

<http://www.control4.com/products/components/complete.htm>

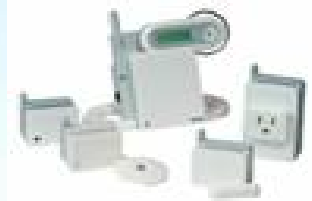

Eaton Home HeartBeat monitoring system

[www.homeheartbeat.com](http://www.homeheartbeat.com)



Chip Sets

- Ember, <http://www.ember.com/index.html>
- ChipCon, <http://www.chipcon.com>
- Freescale, <http://www.freescale.com>



Software, Development Kits

- AirBee, <http://www.airbeewireless.com/products.php>
- Software Technologies Group, <http://www.stg.com/wireless/>



**Crossbow** Technology - Wireless Sensor Networks

[www.xbow.com](http://www.xbow.com)

# **SUMMARY:**

---

- **IEEE 802.15.4 and ZigBee**
  - **Allows Designer to concentrate on end application**
    - **Silicon vendors and ZigBee Alliance take care of transceiver, RF channel and protocol, ZigBee “look and feel”**
  - **Reliable and robust communications**
    - **PHY and MAC outperform all known non-standards-based products currently available**
  - **Flexible network architectures**
  - **Very long primary battery life (months to years to decades)**
  - **Low system complexity. (Due to its architecture)**

# References:

- q IEEE 2003 version of 802.15.4 MAC & Phy standard
  - q <http://standards.ieee.org/getieee802/download/802.15.4-2003.pdf>
- q ZigBee Specification
  - q [http://www.zigbee.org/en/spec\\_download/download\\_request.asp](http://www.zigbee.org/en/spec_download/download_request.asp)
- q 802.15.4 Tutorial
  - q [http://grouper.ieee.org/groups/802/15/pub/2003/Jan03/03036r0P802-15\\_WG-802-15-4-TG4-Tutorial.ppt](http://grouper.ieee.org/groups/802/15/pub/2003/Jan03/03036r0P802-15_WG-802-15-4-TG4-Tutorial.ppt)
- q ZigBee Technology: Wireless Control that Simply Works
  - q <http://www.hometoys.com/htinews/oct03/articles/kinney/zigbee.htm>
- q Home networking with Zigbee
  - q <http://www.embedded.com//showArticle.jhtml?articleID=18902431>
  - q [www.howstuffwork.com](http://www.howstuffwork.com)
  - q <http://en.wikipedia.org/wiki/Zigbee>



# Any Questions ?

Shoot!

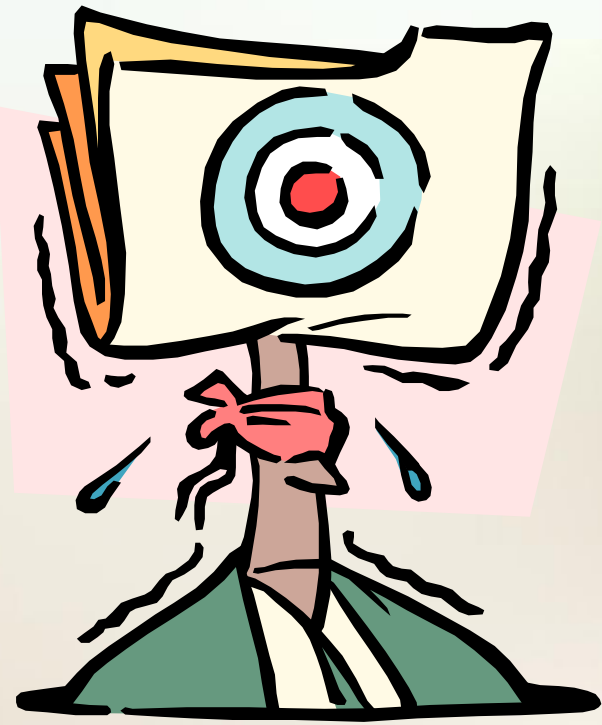



Thank You